

**LB-03 Overhead
Prefeeder**

The standard LB-03 overhead prefeeders are designed to handle small to medium parts, and engineered to interface directly with smaller style parts feeders. A variable speed motor drives the belt at a speed of 23.00 inches per minute.

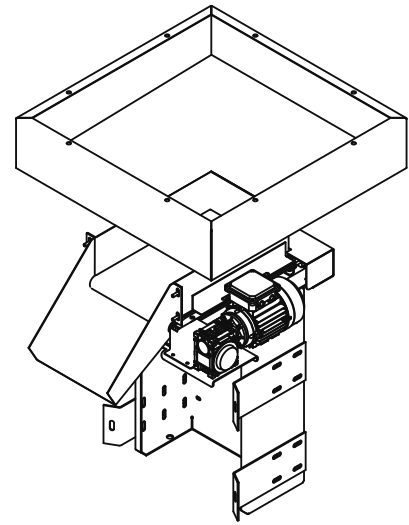

Standard Features:

- All stainless steel construction
- AC motors
- Durable, reinforced black neoprene belt with fiberglass cord
- Feeder mounting brackets

Available Options:

- Hopper safety covers
- Continuous welded seams
- Tan neoprene USDA/FDA dry contact food belt with fiberglass cord (Food Grade Unit)
- NEMA 1 encased controller

Product Specifications		ANSI (inch)	Metric (mm)
A	Overall Height	37	939.8
B	Overall Width	24	609.6
C	Overall Length	25	635.0
D	Hopper Dimensions	24 x 24	609.6 x 609.6
E	Discharge Height	18	457.2
F	Load Height	Varies	Varies
G	Belt Width	10	254
		Motor / Volt/Horsepower	
Prefeeder		208-230/460V • 1/8hp	
Total Equipment Weight		110 lbs / 50 kg	
Hopper Capacity (LB-03)		3 ft ³ / 85 liters	
Hopper Capacity (LB-06)		6 ft ³ / 170 liters	

