

## LB-01 Overhead Prefeeder

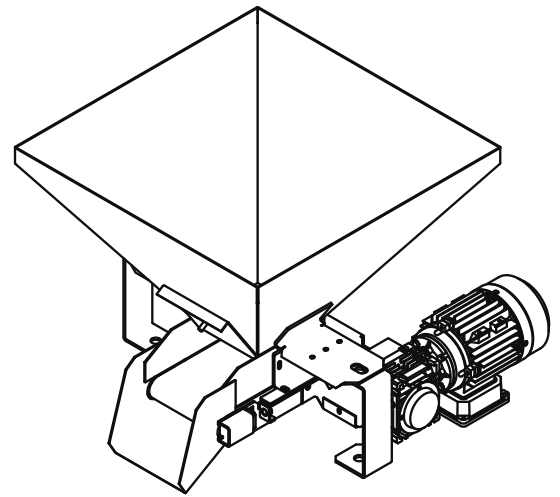

The standard LB-01 overhead prefeeder is specifically designed to handle small, intricate parts using a live bottom belt. It is engineered to interface directly with smaller style parts feeders (such as the FT-20, FT-30). A variable speed motor drives the belt at a speed of 23.00 inches per minute.

### Standard Features:

- All stainless steel construction
- AC motors
- Durable, reinforced black neoprene belt with fiberglass cord
- Feeder mounting brackets

### Available Options:

- Hopper safety covers
- Continuous welded seams
- Tan neoprene USDA/FDA dry contact food belt with fiberglass cord (Food Grade Unit)
- NEMA 1 encased controller

Product Specifications		ANSI (inch)	Metric (mm)
A	Overall Height	17	431.8
B	Overall Width	18	457.2
C	Overall Length	21	533.4
D	Hopper Dimensions	18 x 18	457 x 457
E	Discharge Height	3	76.2
F	Load Height	Varies	Varies
G	Belt Width	5	127
		Motor / Volt/Horsepower	
Prefeeder		208-230/460V • 1/30hp	
Total Equipment Weight		35 lbs / 16 kg	
Hopper Capacity (Prefeeder)		1 ft <sup>3</sup> / 28.32 liters	

