

ET-02 Table-Top Prefeeder

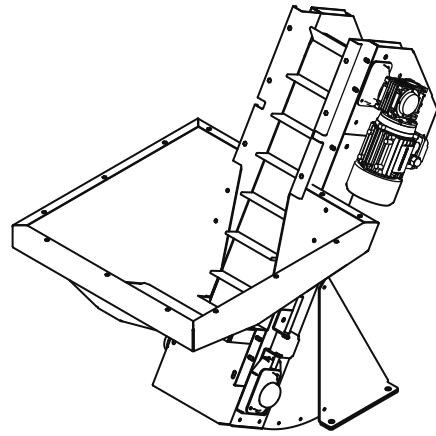

The Shibuya Hoppmann ET-02 Elevating Table Top Prefeeder is designed to handle a variety of small sized, light weight parts with both an adjustable base and head chute to accommodate small product loading and delivery variances. The concept is based on the standard sized elevating prefeeders but has a more compact footprint and is designed to be mounted on top of an existing support table.

Standard Features:

- All stainless steel construction
- Belt (6" width belt, 4" pitch with 1.5" cleat) FDA/USDA approved white 1-ply solid woven polyester fabric with 1/16" thick white PVC coating and PVC cleats
- Hopper clean out door

Available Options:

- Safety cover package
- 18", 24", 36" and 54" elevator extensions available
- Hopper extensions
- Optional belt styles and widths, such as: standard cleat for 85° tilt, blue sanitary belt, super cleat belt

Product Specifications		ANSI (inch)	Metric (mm)
A	Overall Height	74 ± 1.25	1879.6 ± 32
B	Overall Width	42	1066.8
C	Overall Length	73	1854.2
D	Lower Chassis Footprint	63	1600.2
E	Discharge Height	48 ± 1.25	1219.2 ± 32
F	Load Height	36 ± 1.25	914.4 ± 32
G	Belt Width	8	203.2
		Motor / Volt/Horsepower	
Prefeeder		230/280V / 1/5 hp	
Total Equipment Weight		185 lbs / 84 kg	
Hopper Capacity (ET-02)		2 ft ³ / 56 liters	
Hopper Capacity (ET-04)		3 ft ³ / 85 liters	
Hopper Capacity (ET-04)		4 ft ³ / 113 liters	

*Note: These heights are measured from the top of the support table to the top of the hopper.

