

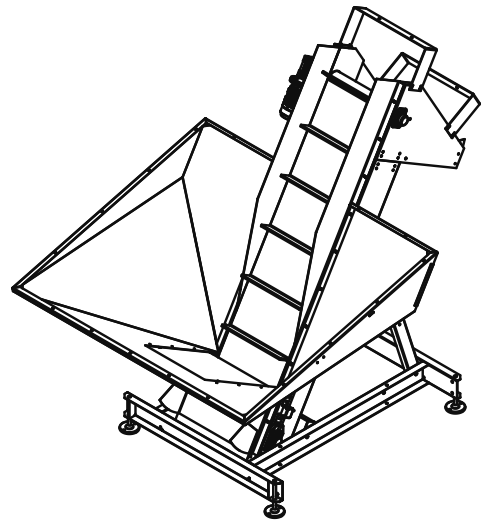

Shibuya Hoppmann

EP-35/50 Elevating Prefeeder



The EP-35/EP-50 elevating prefeeder is designed to handle a variety of large, lightweight parts. Its 35 ft³ capacity hopper delivers product at an average belt speed of 23 feet per minute. The cleated elevator belt has a nominal cleat height of 3.00" and a cleat pitch of 12.00" allowing for maximum product loading. A heavy duty variable speed motor helps to ensure proper product metering. Note: Controllers and mechanical level sensors are not supplied with this unit.

Standard Features:

- All stainless steel construction
- FDA/USDA approved white 1-ply solid woven polyester fabric with 1/16" thick white PVC coating and PVC cleats belting
- Hopper clean out door

Available Options:

- Safety cover package
- 18", 24" 36" and 54" elevator extensions
- Hopper extension for 50 ft³ capacity
- Continuous welded seams
- Washdown motors
- NEMA 1 enclosed controller
- Casters

Product Specifications		ANSI (inch)	Metric (mm)
A	Overall Height	90 ± 2.5	2286.0 ± 64
B	Overall Width	72	1828.8
C	Overall Length	98	2489.2
D	Lower Chassis Footprint	81	2057.4
E	Discharge Height	53 ± 2.5	1346.2 ± 64
F	Load Height	42 ± 2.5	1066.8 ± 64
G	Belt Width	18	457.2
		Motor / Volt/Horsepower	
Prefeeder		230/460V / 1/4 hp	
Total Equipment Weight		1200 lbs / 544 kg	
Hopper Capacity (EP-35)		35 ft ³ / 991 liters	
Hopper Capacity (EP-50)		50 ft ³ / 1416 liters	

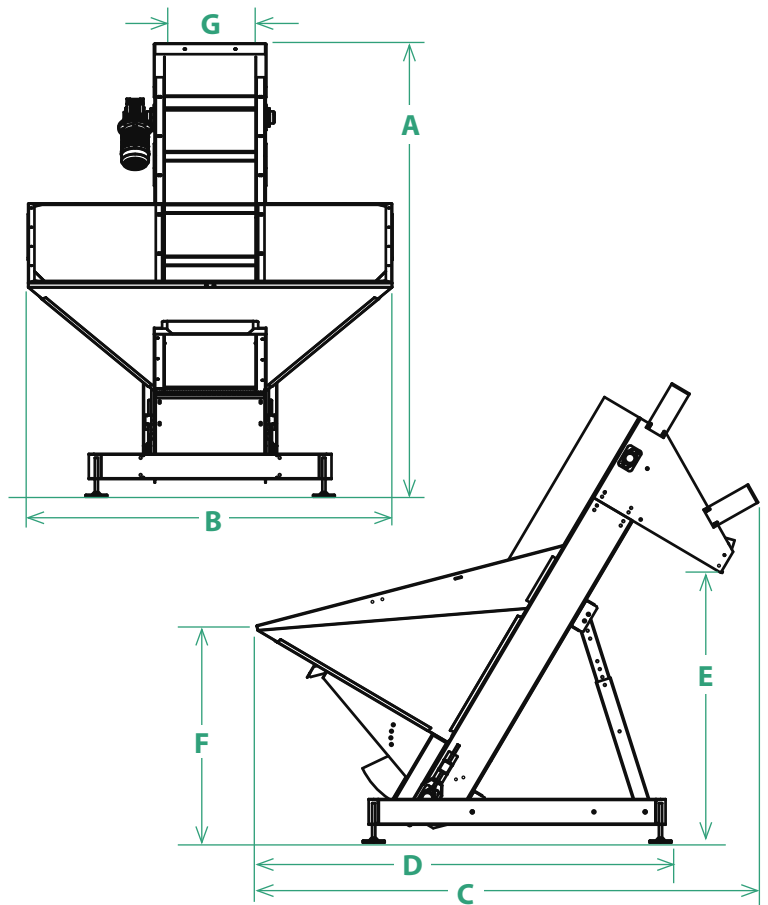

**It is strongly recommended that the frame of the prefeeder be reinforced and/or additional supported for elevator extensions of 54" or greater.*



Sales Office: 1445 Brookville Way, Suite F, Indianapolis, IN 46239 • sales@shibuyahoppmann.com
 Manufacturing: 291 Dillard Road, Madison Heights, VA 24572 • www.shibuyahoppmann.com
 Headquarters: 7849 Coppermine Drive, Manassas, VA 20109 • 1.800.368.3582

