

EP-10 Elevating Prefeeder

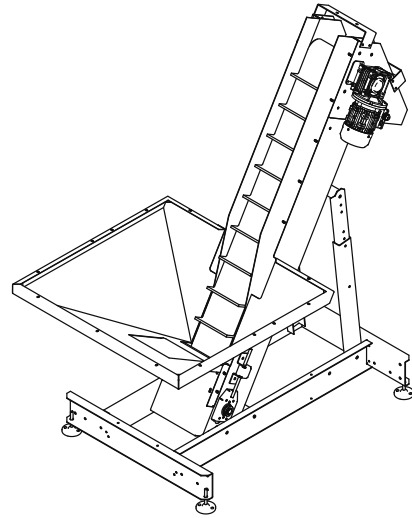

The EP-10/20/30 elevating prefeeder is designed to handle a variety of medium-sized, mid-weight parts. Its 10 ft³ capacity hopper delivers product at an average belt speed of 32'/minute. The 12" wide cleated elevator belt has a nominal cleat height of 2.00" and a cleat pitch of 9.00" allowing for maximum product loading. A heavy duty variable speed motor helps to ensure proper product metering. Note: Controllers and mechanical level sensors are not supplied with this unit.

Standard Features:

- All stainless steel construction
- One piece formed hopper (10 ft³ capacity)
- Belting is FDA/USDA approved white 1-ply solid woven polyester fabric with 1/16" thick white PVC coating and PVC cleats
- Hopper clean out door

Available Options:

- Safety cover package
- 18", 24" 36" and 54" elevator extensions
- Hopper extensions for 20 and 30 ft³ capacity
- Continuous welded seams (EP-20/30)
- Washdown motors
- NEMA 1 enclosed controller
- Hopper agitator
- Casters

Product Specifications		ANSI (inch)	Metric (mm)
A	Overall Height	77 ± 1.25	1955.8 ± 32
B	Overall Width	46	1168.4
C	Overall Length	75	1905
D	Lower Chassis Footprint	62	1574.8
E	Discharge Height	49 ± 1.25	1244.6 ± 32
F	Load Height	38 ± 1.25	965.2 ± 32
G	Belt Width	12	304.8
		Motor / Volt/Horsepower	
Prefeeder		230/460V / 1/4 hp	
Total Equipment Weight		740 lbs / 336 kg	
Hopper Capacity (EP-08)		10 ft ³ / 283 liters	
Hopper Capacity (EP-15)		20 ft ³ / 556 liters	
Hopper Capacity (EP-25)		30 ft ³ / 848 liters	

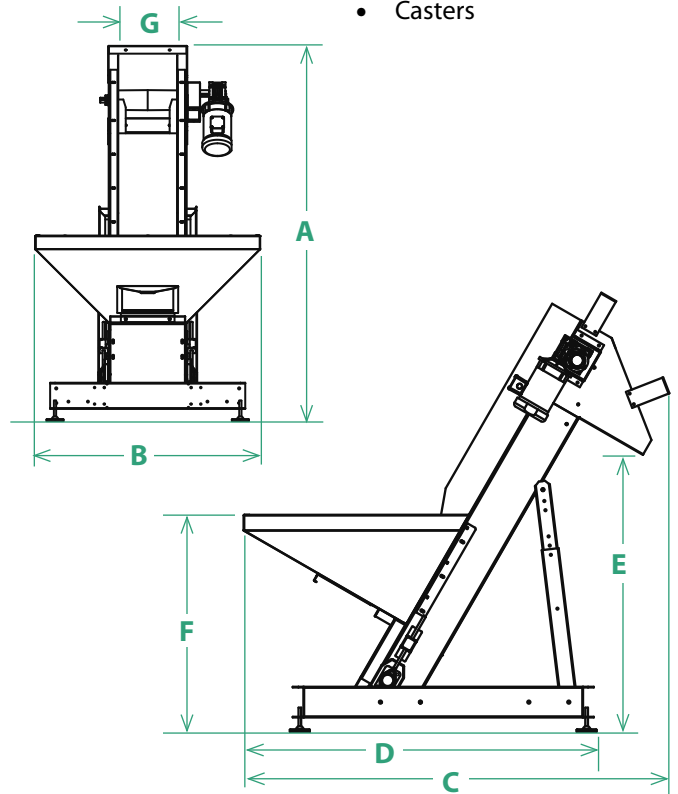

**It is strongly recommended that the frame of the prefeeder be reinforced and/or additional supported for elevator extensions of 54" or greater.*