

EP-08 Elevating Prefeeder

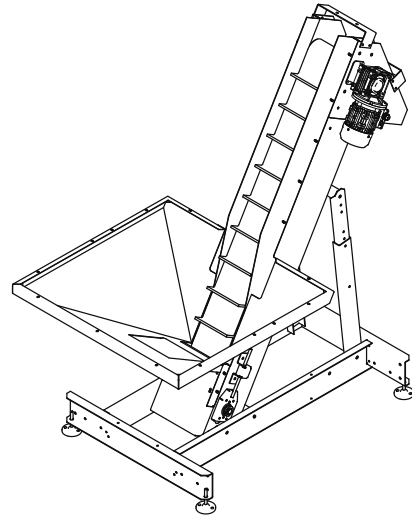

The EP-08/EP-15/EP-25 elevating prefeeder is designed to handle a variety of medium-sized, light weight parts. Its 8 ft³ capacity hopper delivers product at an average belt speed of 32'/minute. The cleated elevator belt has a nominal cleat height of 2.00" and a cleat pitch of 6.00" allowing for maximum product loading. A heavy duty variable speed motor helps to ensure proper product metering. Note: Controllers and mechanical level sensors are not supplied with this unit.

Standard Features:

- All stainless steel construction
- One piece formed hopper (8 ft³ capacity)
- Belting is FDA/USDA approved white 1-ply solid woven polyester fabric with 1/16" thick white PVC coating and PVC cleats
- Hopper clean out door

Available Options:

- Safety cover package
- 18", 24" 36" and 54" elevator extensions
- Hopper extensions for 15 and 25 ft³ capacity
- Continuous welded seams (EP-15/25)
- Washdown motors
- NEMA 1 enclosed controller
- Hopper agitator
- Casters

Product Specifications		ANSI (inch)	Metric (mm)
A	Overall Height	74 ± 1.25	1879.6 ± 32
B	Overall Width	42	1066.8
C	Overall Length	73	1854.2
D	Lower Chassis Footprint	63	1600.2
E	Discharge Height	48 ± 1.25	1219.2 ± 32
F	Load Height	36 ± 1.25	914.4 ± 32
G	Belt Width	8	203.2
		Motor / Volt/Horsepower	
Prefeeder		230/460V / 1/4 hp	
Total Equipment Weight		720 lbs / 327 kg	
Hopper Capacity (EP-08)		8 ft ³ / 227 liters	
Hopper Capacity (EP-15)		15 ft ³ / 425 liters	
Hopper Capacity (EP-25)		25 ft ³ / 708 liters	

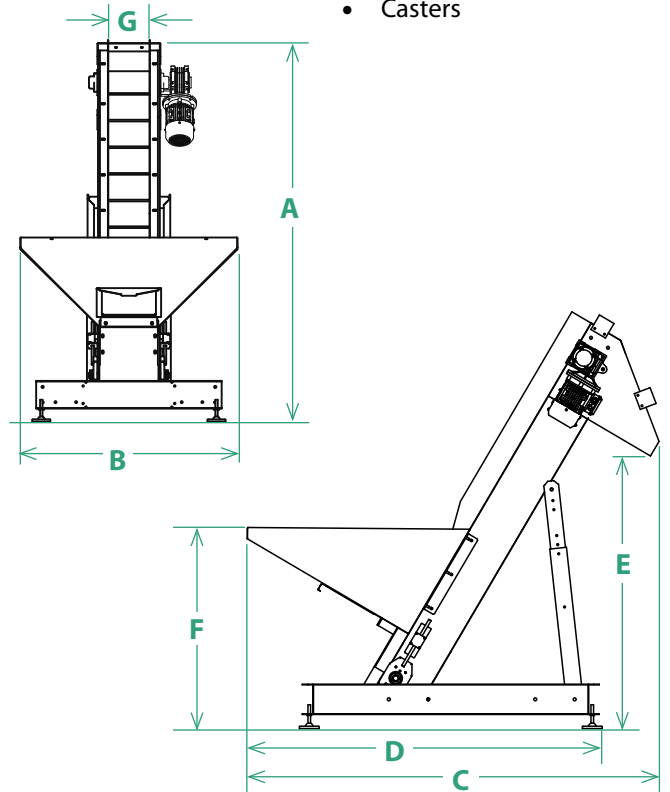

**It is strongly recommended that the frame of the prefeeder be reinforced and/or additional supported for elevator extensions of 54" or greater.*