

EP-04 Elevating Prefeeder

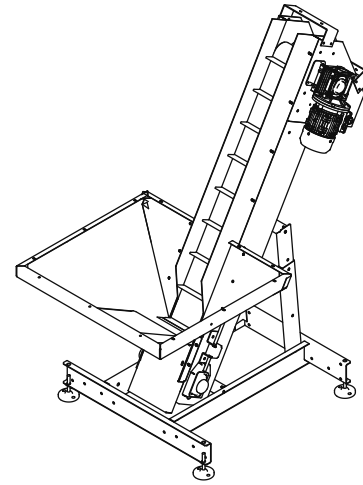

The EP-04/EP-06 elevating prefeeder is designed to handle a variety of small, lightweight parts. Its 4 ft³ capacity hopper delivers product at an average belt speed of 35'/minute. The cleated elevator belt has a nominal cleat height of 1.50" and a cleat pitch of 6.00" allowing for maximum product loading. A heavy duty variable speed motor helps to ensure proper product metering. Note: Controllers and mechanical level sensors are not supplied with this unit.

Standard Features:

- All stainless steel construction
- AC motor
- 6" wide belt with 4" pitch and 1.5" cleat. FDA/USDA approved white 1-ply solid woven polyester fabric with 1/16" thick white PVC coating and PVC cleats
- Hopper clean out door

Available Options:

- Safety cover package
- 18", 24" 36" and 54" elevator extensions
- Hopper extensions
- Optional belt styles and widths
- Hopper agitator

Product Specifications		ANSI (inch)	Metric (mm)
A	Overall Height	66 ± 1.25	1676.4
B	Overall Width	36	914.4
C	Overall Length	62	1674.8
D	Lower Chassis Footprint	47	1193.8
E	Discharge Height	43 ± 1.25	1092.2 ± 32
F	Load Height	32 ± 1.25	812 ± 32
G	Belt Width	6	152.4
		Motor / Volt/Horsepower	
Prefeeder		AC 208-230/460V • 1/4hp	
Total Equipment Weight		250 lbs / 113.4.9 kg	
Hopper Capacity (EP-04)		4 ft ³ / 113 liters	
Hopper Capacity (EP-06)		6 ft ³ / 170 liters	

