

EH-08 Prefeeder

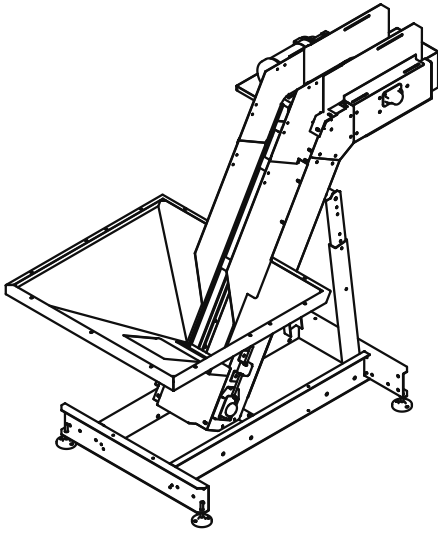

The EH-08/15/25 horizontal discharge, elevating prefeeder is designed to handle medium-sized parts. Using a modular, plastic, cleated chain to vertically and horizontally transport parts, this prefeeder allows the discharge to be closer to the bowl, eliminating potential scuffing or scraping of parts while being able to reach over existing equipment. A heavy duty variable speed motor helps to ensure proper product metering. Note: Controllers and mechanical level sensors are not supplied with this unit.

Standard Features:

- All stainless steel construction
- Modular plastic chain
- Hopper clean out door
- Elevator and hopper covers
- One piece formed hopper (8 ft³ capacity)

Available Options:

- Elevator extensions*
- Hopper extension for 15 and 25 ft³ capacity
- Continuous welded hopper seams (EH-15/25)
- Washdown motor
- NEMA 1 encased controller
- Pneumatic hopper agitator
- Casters

Product Specifications		ANSI (inch)	Metric (mm)
A	Overall Height	69 ± 1.25	1752.6 ± 32
B	Overall Width	42	1066.8
C	Overall Length	82	2082.8
D	Lower Chassis Footprint	63	1600.2
E	Discharge Height	53 ± 1.25	1346.2 ± 32
F	Load Height	38 ± 1.25	965.2 ± 32
G	Belt Width	8	203.2
		Motor / Volt/Horsepower	
Prefeeder		230/460V / 1/3 hp	
Total Equipment Weight		1000 lbs / 454 kg	
Hopper Capacity (EP-08)		8 ft ³ / 227 liters	
Hopper Capacity (EP-15)		15 ft ³ / 425 liters	
Hopper Capacity (EP-25)		25 ft ³ / 708 liters	

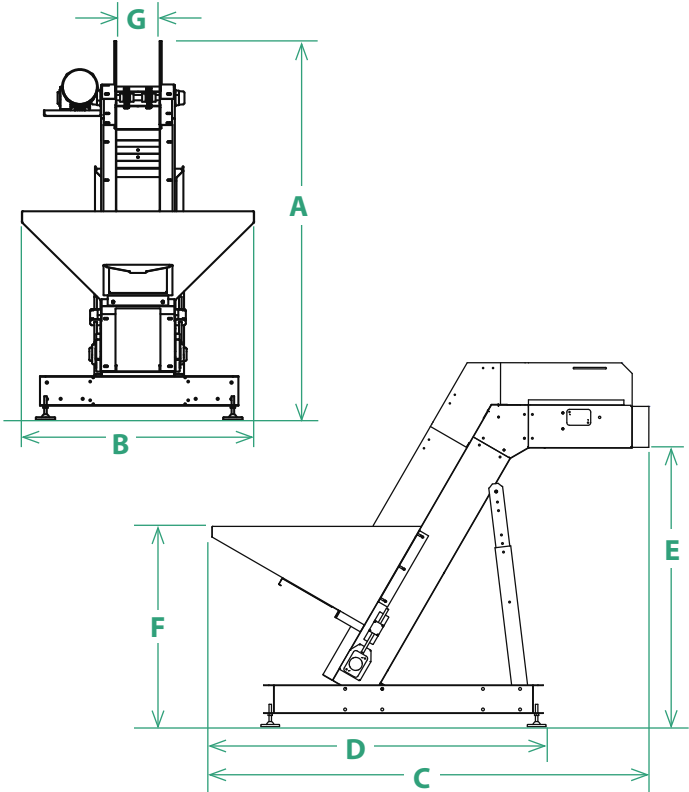

*It is strongly recommended that the frame of the prefeeder be reinforced and/or additional supported for elevator extensions of 36" or greater.

