



Product Overview:

Shibuya Hoppmann's standard FT-60 rigid disc centrifugal feeder is designed to feed a variety of products with its unique bowl design. Product is metered into the bowl and brought out to the bowl rim where a series of qualifiers gently orient the part for transfer to various downstream inline devices. Note: Tooling is not included with this unit.

Part Number	FT601RLASA
Motor Style	AC
Motor Voltage	208-230/460V
Horsepower	3/4hp
Total Equipment Weight	1400 lbs. / 635 kg

Standard Features:

- All stainless steel exterior construction
- FDA approved ABS vacuum formed disc
- Teflon Hardcoat Anodized aluminium bowl

Available Options:

- Polycarbonate covers
- Dual motor drive system
- Washdown motor(s)
- NEMA 1 encased controller

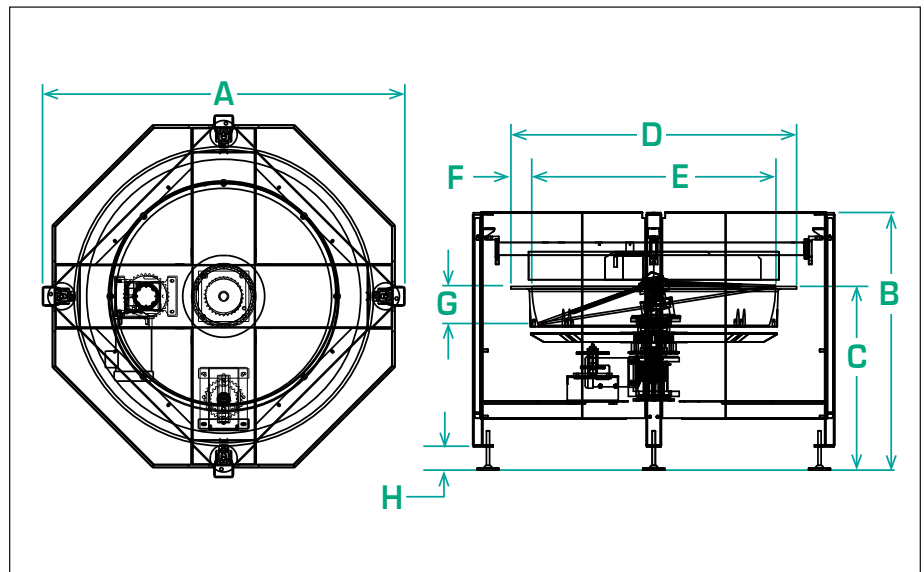

Recommended Accessories:

Clockwise: Backup Ring	BUCWFT60SU
Counter-Clockwise: Backup Ring	BUCCT60SU

Product Specifications		ANSI	Metric
A	Outside Diameter	85.12"	2162.0mm
B	Overall Height	50.13"	1273.3mm
C	Bowl Discharge Height	35.76"	908.3mm
D	Bowl Outside Diameter	70.00"	1778.0mm
E	Bowl Inside Diameter	60.00"	1524.0mm
F	Rim Width	5.00"	127.0mm
G	Bowl Depth	10.00"	254.0mm
H	Level Foot Adjustment	3.58"	90.9mm