



Part Number	FT501RLASA
Motor Style	AC
Motor Voltage	208-230/460V
Horsepower	1/2hp
Total Equipment Weight	1050 lbs. / 476 kg

Standard Features:

- All stainless steel exterior construction
- FDA approved ABS vacuum formed disc
- Teflon Hardcoat Anodized aluminium bowl

Available Options:

- Polycarbonate covers
- Dual motor drive system
- Washdown motor(s)
- NEMA 1 encased controller

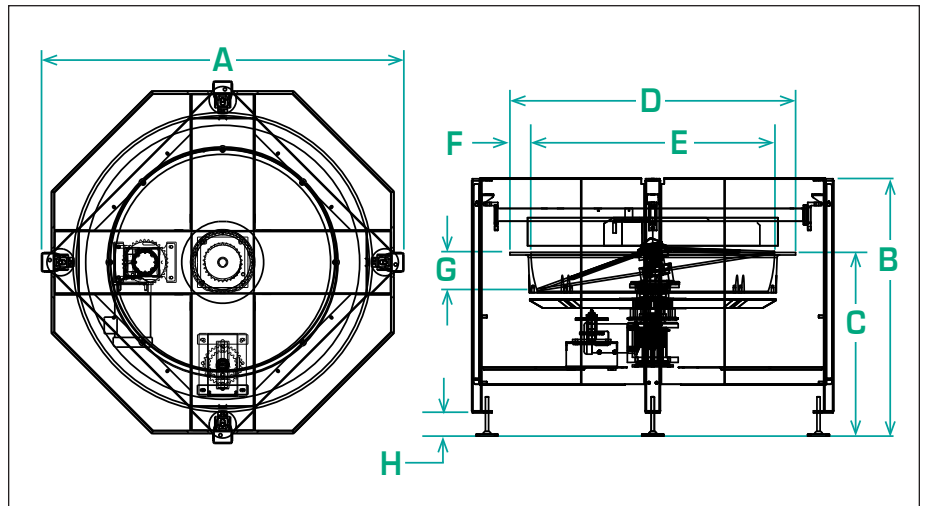

Recommended Accessories:

Clockwise: Backup Ring	BUCWFT50SU
Counter-Clockwise: Backup Ring	BUCCFT50SU

Product Specifications		ANSI	Metric
A	Outside Diameter	71.00"	1803.4mm
B	Overall Height	50.45"	1281.4mm
C	Bowl Discharge Height	36.00"	914.4mm
D	Bowl Outside Diameter	56.00"	1422.4mm
E	Bowl Inside Diameter	47.75"	1212.9mm
F	Rim Width	4.13"	104.9mm
G	Bowl Depth	7.88"	200.2mm
H	Level Foot Adjustment	4.57"	116.1mm