



### Product Overview:

Shibuya Hoppmann's standard FT-40 rigid disc centrifugal feeder is designed to feed a variety of products with its unique bowl design. Product is metered into the bowl and brought out to the bowl rim where a series of qualifiers gently orient the part for transfer to various downstream inline devices. Note: Tooling is not included with this unit.

Part Number	FT401RLASA
Motor Style	AC
Motor Voltage	230/460V
Horsepower	1/2hp
Total Equipment Weight	850 lbs. / 385 kg

### Standard Features:

- All stainless steel exterior construction
- FDA approved ABS vacuum formed disc
- Teflon Hardcoat Anodized aluminium bowl

### Available Options:

- Polycarbonate covers
- Dual motor drive system
- Washdown motor(s)
- NEMA 1 encased controller

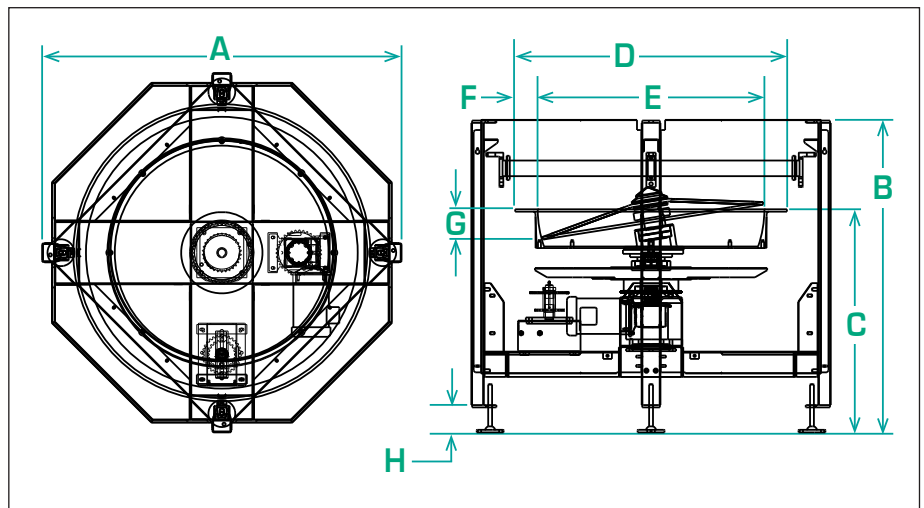

### Recommended Accessories:

Clockwise: Backup Ring	BUCWFT40SU
Counter-Clockwise: Backup Ring	BUCCFT40SU

Product Specifications		ANSI	Metric
A	Outside Diameter	57.48"	1460.0mm
B	Overall Height	49.88"	1267.0mm
C	Bowl Discharge Height	35.68"	906.3mm
D	Bowl Outside Diameter	43.46"	1103.9mm
E	Bowl Inside Diameter	36.25"	920.8mm
F	Rim Width	3.61"	91.7mm
G	Bowl Depth	6.20"	157.5mm
H	Level Foot Adjustment	4.00"	101.6mm