

Product Overview:

Shibuya Hoppmann's standard FT-20 rigid disc centrifugal feeder is designed to feed a variety of products with its unique bowl design. Product is metered into the bowl and brought out to the bowl rim where a series of qualifiers gently orient the part for transfer to various downstream inline devices. Note: Tooling is not included with this unit.

Part Number	FT201RLASA
Motor Style	AC
Motor Voltage	230/460V
Horsepower	1/3hp
Total Equipment Weight	150 lbs. / 68 kg

Standard Features:

- All stainless steel exterior construction
- FDA approved ABS vacuum formed disc
- Teflon Hardcoat Anodized aluminium bowl

Available Options:

- Polycarbonate covers
- Dual motor drive system
- Washdown motor(s)
- NEMA 1 encased controller

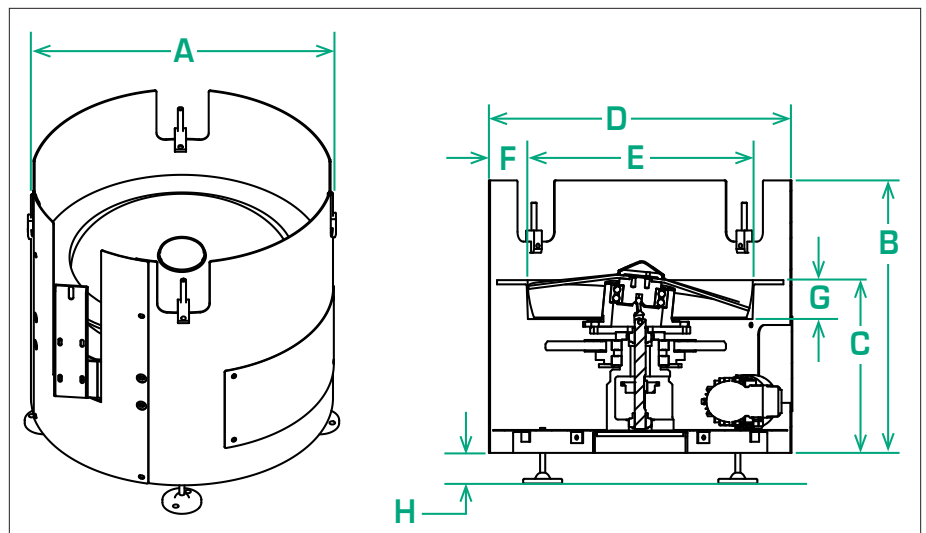

Recommended Accessories:

Clockwise: Square Tooling Frame and Backup Ring	BUCWFT20SU
Counter-Clockwise: Square Tooling Frame and Backup Ring	BUCCF20SU

Product Specifications		ANSI	Metric
A	Outside Diameter	27.28"	692.9mm
B	Overall Frame Height	24.50"	622.3mm
C	Bowl Discharge Height *	15.54"	394.7mm
D	Bowl Outside Diameter	25.75"	654.0mm
E	Bowl Inside Diameter	20.25"	514.0mm
F	Rim Width	2.75"	70.0mm
G	Bowl Depth	2.50"	64.0mm
H	Level Foot Adjustment	2.75" *	±69.9mm *

* The leveling foot has a vertical adjustment of $\pm 1.75"$, allowing for a height variation between 1.00" and 4.50". This may alter the discharge height.