

## FT-15-HD Heavy Duty Centrifugal Feeder



\*Shown with optional prefeeder

### Product Overview:

The new Hoppmann Heavy Duty FT-15 centrifugal feeder is engineered to handle small, metal parts traditionally oriented in vibratory feeders. The FT-15-HD offers greatly reduced noise output and smooth operation in comparison to a vibratory feeder, extremely accurate operational tolerances, and easily handles multiples sizes of parts with minor change over and no reduction in feed rate. Designed on the same premise as our standard centrifugal feeder, the Heavy Duty feeder uses motors for speed, not springs and vibrators, which limits maintenance (retuning) and replacement requirements.

Part Number	FT151RLDSA	FT151RLASA
Motor Style	DC	AC
Motor Voltage	90V	230/460V
Horsepower	1/15 hp	1/15 hp
Total Equipment Weight	134 lbs. / 61 kg	

### Standard Features:

- All stainless steel exterior construction
- Adjustable tooling frame
- Polyurethane hybrid bowl and disc
- Ball bearing spindle
- Poly-V belt drive system

### Available Options

- Polycarbonate covers
- Dual motor drive system
- NEMA 1 encased controller
- Washdown motor(s)

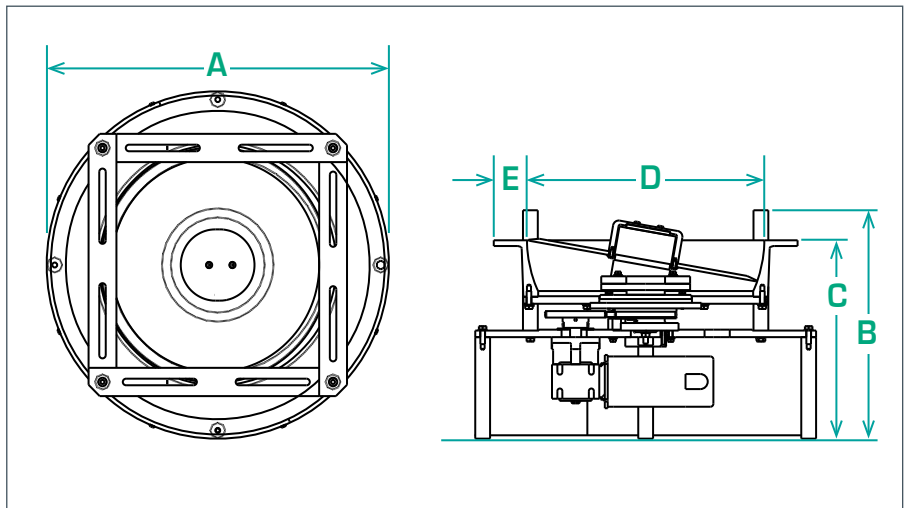

Product Specifications		ANSI	Metric
A	Overall Diameter	23.00"	584.0mm
B	Overall Height	16.00" ± 1"	405.0 ± 25mm
C	Bowl Discharge Height	12.75" ± 1"	324.0 ± 25mm
D	Bowl Inner Diameter	16.00"	406.0mm
E	Rim Width	2.25"	57.0mm