

Model EP Series Elevating Prefeeders

ANSI/Metric Installation & Maintenance Manual

Refer all servicing to qualified personnel.

This manual is intended for use by qualified mechanics and electricians who install or service the Hoppmann EP Series Elevating Prefeeders manufactured **after March, 2015**.



Record your serial plate information here for future reference



Model Number

Serial Number/Date

Third Edition, Revision 1, All Rights Reserved.
Copyright 2018 by Shibuya Hoppmann Corporation.

Duplication of this manual, in whole or in part, requires prior written consent from Shibuya Hoppmann Corporation.

Headquarters
7849 Coppermine Dr.
Manassas, VA
20109
540.829.2564 t
800.368.3582 t
540.829.1726 f

Sales
1445 Brookville Way
Suite F
Indianapolis, IN 46239
317.322.0754 t
800.368.3582 t
317.322.0794 f

Manufacturing
291 Dillard Road
Madison Heights, VA
24572
434.929.4746 t
800.368.3582 t
434.929.4959 f

Quick Start

Thank You for Choosing Shibuya Hoppmann

Thank you for purchasing a system from Shibuya Hoppmann. Our prefeeders, feeders, and automated systems possess an industry-wide reputation of excellence for their quiet and rapid handling of parts, ease of use and low maintenance requirements.

About This Manual

Assumptions

Shibuya Hoppmann Corporation assumes that all procedures contained in this manual will be performed by a qualified mechanic or electrician who must install or service the EP-Series prefeeders. All procedures in this manual should be performed by qualified personnel or under their direction.

Models Covered

This manual covers four (4) styles of prefeeders models: **EP-04/06 Elevating Prefeeder, EP-08/15/25 Elevating Prefeeder, EP-10/20/30 Elevating Prefeeder and the EP-35/50 Elevating Prefeeder.** If you are unsure of your model, locate the inventory number on the serial plate of your prefeeder.

Before You Start

Tools You Will Need

The EP Series prefeeders are both "soft ANSI" and metric construction, meaning that metric threads and hardware are used throughout. The prefeeders require metric tools for repair and/or adjustment.



Equipment Improvements & Document Revisions Notice

Shibuya Hoppmann Corporation (SHC) continually improves its products, and reserves the right to change or discontinue specifications and designs shown in this manual without notice and without incurring obligation. Occasionally older versions of equipment may have different spare parts/replacement parts requirements. Please be sure to contact SHC before ordering specific parts for older style prefeeders. SHC has made every effort to verify the information contained in this manual, but reserves the right to correct any error at the time of the manual's next revision. 8.2018.

Important - Read First

Caution Symbols & Messages

Caution Symbols and Messages

Caution symbols and messages in this manual call attention to hazardous voltages, moving parts, and other hazardous conditions. Please understand what the different warning labels and indicators refer to and how to avoid possible injury and/or damage to personnel and equipment.



The lightning bolt symbol serves as a caution to denote possible personal injury and/or damage to the equipment due to electrical hazards.



The exclamation point symbol serves as a caution to denote possible personal injury and/or damage to the equipment.

Danger - Electrical/Voltage Hazard



The voltages in this system can cause death or serious injury. **Service should be performed only by qualified service personnel.** Read the safety precautions in Chapter 2 before operating or servicing this system, including any Lockout/Tagout procedures.



Danger - Mechanical Hazard



To reduce the risk of injury from moving parts, keep all safety covers in place, secure loose clothing, and wear safety glasses or other protective eye wear when operating machine.



To reduce the risk of injury from moving parts, padlock and tag the main electrical and pneumatic disconnects before adjusting or replacing change parts or performing mechanical maintenance. Ensure that power is off and cannot be reactivated accidentally.



Table of Contents

Chapter Name		Page		
Quick Start	About this Manual	2		
	Before You Start	2		
	Caution Symbols and Messages	3		
	Table of Contents	5		
<hr/>				
1	Description and Specifications	The EP Series Elevating Prefeeder: Overview	7	
		EP-04/EP-06 Elevating Prefeeder Specifications	8	
		EP-08/15/25 Elevating Prefeeder Specifications	10	
		EP-10/20/30 Elevating Prefeeder Specifications	12	
		EP-35/50 Elevating Prefeeder Specifications	14	
		Figures:		
		Figure 1-1. EP Series Typical Elevating Prefeeder - EP/08 Shown	7	
		Table 1-1. EP-04/06 Specifications	8	
		Figure 1-2. EP-04/06 Dimension Views	9	
	Table 1-2. EP-04/06 Dimension Specifications	9		
	Table 1-3. EP-08/15/25 Specifications	10		
	Figure 1-3. EP-08/15/25 Dimension Views	11		
	Table 1-4. EP-08/15/25 Dimension Specifications	11		
	Table 1-5. EP-10/20/30 Specifications	12		
	Figure 1-4. EP-10/20/30 Dimension Views	13		
	Table 1-6. EP-10/20/30 Dimension Specifications	13		
	Table 1-7. EP-35/50 Specifications	14		
	Figure 1-5. EP-35/50 Dimension Views	15		
	Table 1-8. EP-35/50 Dimension Specifications	15		
	<hr/>			
2	Safety Precautions	Safety Precautions	17	
		Specific Warnings & Cautions	17	
		Operating and Maintenance: Do's and Don'ts	17	
<hr/>				
3	Installation & Start-Up	If the Prefeeder is Already Set UP	19	
		Unpacking and Inspection	19	
		Physical Setup	20	
		Installing Hopper Extensions	20	
		Installing Elevator Extensions	21	
		Replacing/Installing Belts and Belt Extensions	28	
		Level Sensor	30	
		Establishing the Correct Prefeeder Speed	31	
		Wiring Schematics	31	

Table of Contents

3	Chapter Name	Page	
3	Installation & Start-Up (Continued)	Figures:	
		Figure 3-1. Sample Serial Plate	19
		Figure 3-2. Take-Up Pulley	21
		Figure 3-3. Remove Lacing Pin to Remove Belt	21
		Figure 3-4. Disconnect Power	22
		Figure 3-5. Pull Belt out to Remove Head	22
		Figure 3-6. Left Hand and Right Hand Exit Guides	23
		Figure 3-7. Extension Kit for Prefeeder Extension	24
		Figure 3-8. Attach New Belt Extension to Existing Belt	25
		Figure 3-9. Tracking Adjustment of Belt Made to Belt Tensioner	26
		Figure 3-10. Adjusting the Dump Height Suspension Points	26
		Table 3-1. Dump Height Reference Chart	27
		Figure 3-11. Re-Installing Lacing Pin	28
		Figure 3-12. Tracking Adjustment of Belt Made to Belt Tensioner	26
		Table 3-2. One Piece Extensions - Belt Replacement	29
	Table 3-3. Extension Only - Belt Replacement	30	
	Figure 3-13. Wiring Diagram - AC Prefeeder	31	
	Figure 3-14. Wiring Diagram - DC Prefeeder	32	
4	Preventive Maintenance	Upper Drive Pulley	33
		Lower Take-Up Pulley	35
		Reducers	36
		Routine Cleaning	36
		Figures:	
		Figure 4-1. Drive Pulley (Head) with DC Motor/Reducer	33
		Figure 4-2. Drive Pulley (Head) with AC Gear Motor	34
	Figure 4-2. Lower Take-Up Pulley Sub-Assembly	35	
5	Replacement Parts	Replacement Parts	37
		EP-04/06 Elevating Prefeeder	38
		EP-08/15/25 Elevating Prefeeder	40
		EP-10/20/30 Elevating Prefeeder	42
		EP-35/50 Elevating Prefeeder	43
		Figures:	
			Figure 5-1. Sample Serial Plate
6	Warranty	Warranty	45

Description & Specifications

1

The EP Series Elevating Prefeeder: Overview

Function The EP Series Elevating Prefeeder are designed to load parts into a feeder or other equipment for singulation and/or orientation. The supply hopper capacity ranges from 4 cubic feet (EP-04) to 50 cubic foot (EP-50).

Parts are loaded into the hopper at floor level. The product is then gently raised out of the hopper by means of a cleated belt and metered into either the recipient feeder bowl or other equipment on demand of a bowl level sensor. Refer to Figure 1-1 for a diagram of the various parts of an elevating prefeeder.

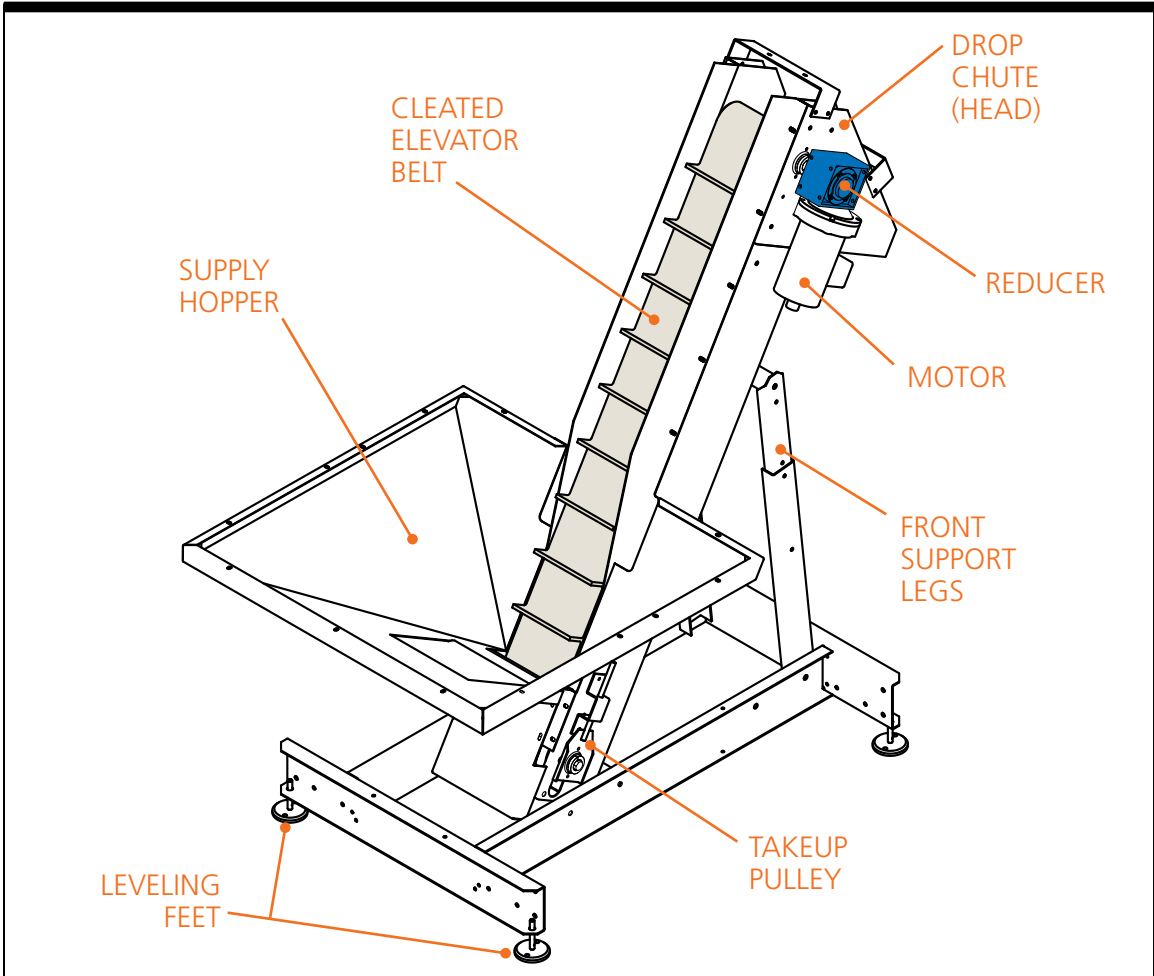

Figure 1-1. EP Series Typical Elevating Prefeeder - EP-08 Shown

EP-04/EP-06 Elevating Prefeeder Specifications

Standard Features The stainless steel constructed EP-04 and EP-06 elevating prefeeders come standard with an FDA/USDA approved white 1-ply solid woven polyester fabric belt, with .156" thick white PVC coating and standard 1.50" tall cleats.

Optional Features Elevator extension, hopper extensions, continuous welded hoppers, integrated safety covers, washdown motors, NEMA 1 encased controller, pneumatic hopper agitators and casters are optional equipment.

Specifications Please refer to the tables below for EP-04/06 specifications:

Specifications	DC	AC
Motor Size	1/4hp	1/4hp
Motor Frame Size	56C	56C
Supply Voltage	90VDC	230/460 VAC
Average Belt Speed	35'/min.	10.67 meters/min.
Cleat Height (Nominal)	1.50 "	38.10mm
Cleat Pitch	6.00 "	152.40mm
EP-04 Hopper Capacity	4 ft ³	113 liters
EP-06 Hopper Capacity	6 ft ³	170 liters

Table 1-1. EP-04/06 Specifications

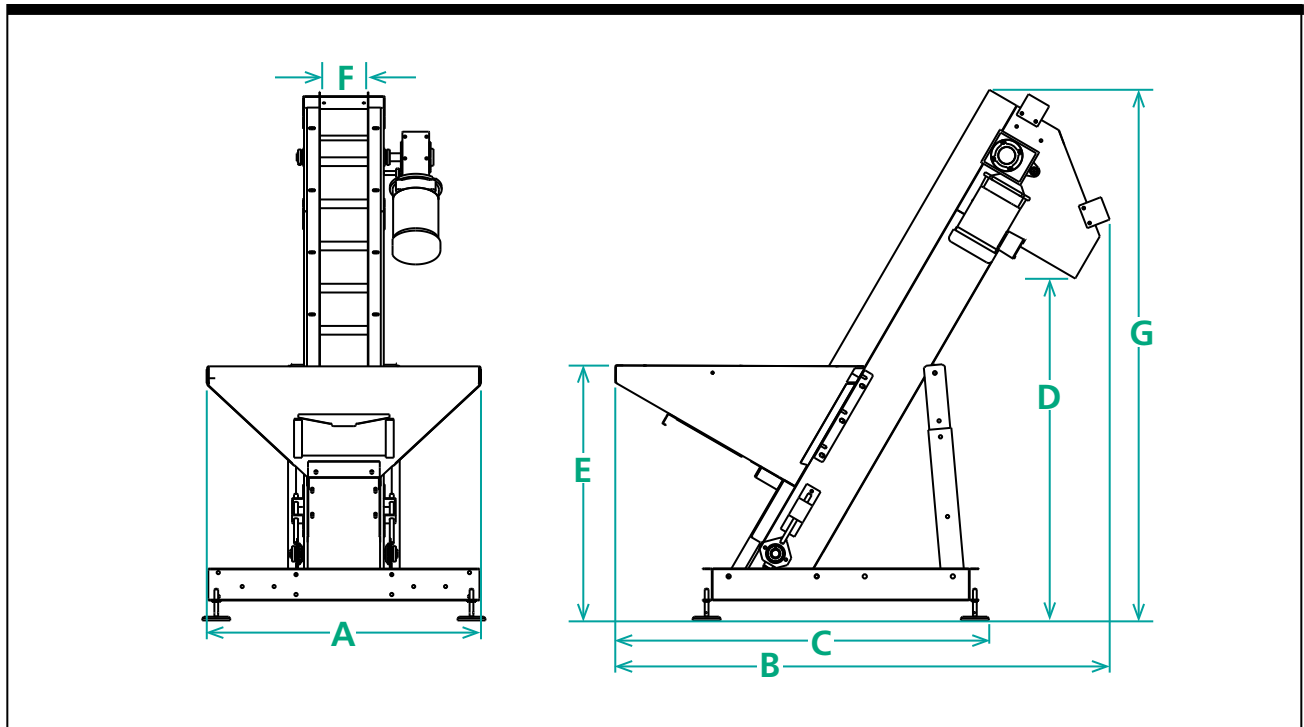

Figure 1-2. EP-04/06 Dimension Views

Dimension Specifications		ANSI	Metric
A	Overall Width	34.22 "	869.2mm
B	Overall Length	61.75 "	1568.5mm
C	Lower Chassis Footprint	46.66 "	1185.2mm
D	Dump Height (Adjustable)	42.69 "	1084.3mm
E	Hopper Load Height (EP-04)	31.86 "	809.2mm
E	Hopper Load Height (EP-06)	35.86 "	910.8mm
F	Belt Width	6.00 "	152.0mm
G	Overall Height	66.27 "	1683.3mm
H	Level Foot Adjustment	2.00 "	51.0mm
Overall Weight		250 lbs.	113.4 kg

Table 1-2. EP-04/06 Dimension Specifications

EP-08/EP-15/EP-25 Elevating Prefeeder Specifications

Standard Features The stainless steel constructed EP-08/15/25 elevating prefeeders come standard with an FDA/USDA approved white 1-ply solid woven polyester fabric belt, with .156" thick white PVC coating and standard 2.00" tall cleats, hopper cleanout door and one piece formed hopper (8 cubic foot standard).

Optional Features Elevator extensions, hopper extensions, continuous welded hoppers (for EP-15 and EP-25), integrated safety covers, washdown motors, NEMA 1 encased controller, pneumatic hopper agitators and casters are optional equipment.

Specifications Please refer to the tables below for EP-08/15/25 specifications:

Specifications	DC	AC
Motor Size	1/4hp	1/4hp
Motor Frame Size	56C	56C
Supply Voltage	90VDC	230/460VAC
Average Belt Speed	32'/min.	9.75 meters/min.
Cleat Height (Nominal)	2.00"	50.80mm
Cleat Pitch	6.00"	152.40mm
EP-08 Hopper Capacity	8 ft ³	227 liters
EP-15 Hopper Capacity	15 ft ³	425 liters
EP-25 Hopper Capacity	25 ft ³	708 liters

Table 1-3. EP-08/15/25 Specifications

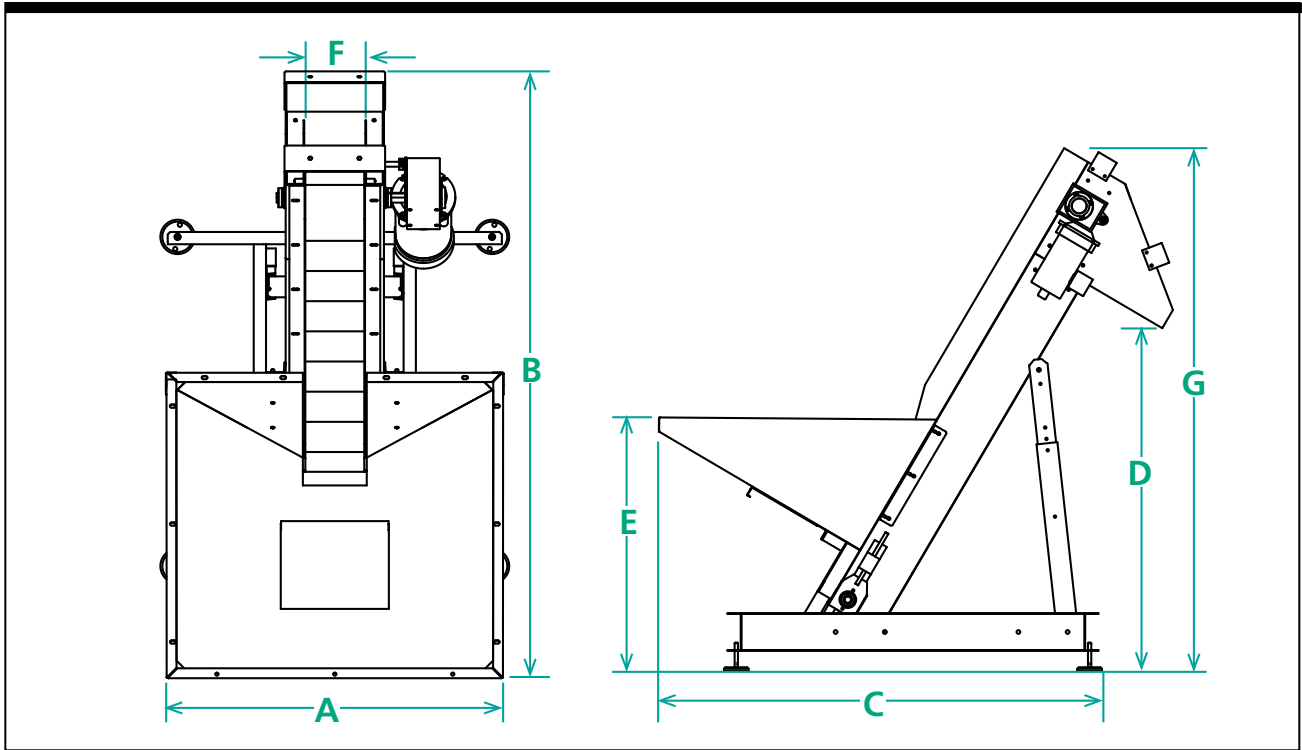

Figure 1-3. EP-08/15/25 Dimension Views

Dimension Specifications		ANSI	Metric
A	Overall Width	42.13 "	1070.1mm
B	Overall Length	73.11 "	1857.0mm
C	Lower Chassis Footprint	63.01 "	1600.5mm
D	Dump Height (Adjustable)	48.70 "	1237.0mm
E	Hopper Load Height (EP-08)	36.00 "	914.4mm
E	Hopper Load Height (EP-15)	43.00 "	1092.2mm
E	Hopper Load Height (EP-25)	52.00 "	1320.8mm
F	Belt Width	8.00 "	203.2mm
G	Overall Height	74.30 "	1887.2mm
Overall Weight		720 lbs.	327kg

Table 1-4. EP-08/15/25 Dimension Specifications

EP-10/20/30 Elevating Prefeeder Specifications

Standard Features The EP-10/20/30 elevating prefeeder is designed to handle a variety of medium-sized, mid-weight parts. Its 10 ft³ capacity hopper delivers product at an average belt speed of 32'/minute. The 12" wide cleated elevator belt has a nominal cleat height of 2.00" and a cleat pitch of 9.00" allowing for maximum product loading. A heavy duty variable speed motor helps to ensure proper product metering.

Optional Features Elevator extensions, hopper extensions, integrated safety covers, washdown motors, NEMA 1 encased controller, pneumatic hopper agitators and casters are optional equipment.

Specifications Please refer to the tables below for EP-10/20/30 specifications:

Specifications	DC	AC
Motor Size	1/4hp	1/4hp
Motor Frame Size	56C	56C
Supply Voltage	90VDC	230/460VAC
Average Belt Speed	32'/min.	9.75 meters/min.
Cleat Height (Nominal)	2.00 "	50.80mm
Cleat Pitch	9.00 "	228.6mm
EP-10 Hopper Capacity	10 ft ³	283 liters
EP-20 Hopper Capacity	20 ft ³	566 liters
EP-30 Hopper Capacity	30 ft ³	850 liters

Table 1-5. EP-10/20/30 Specifications

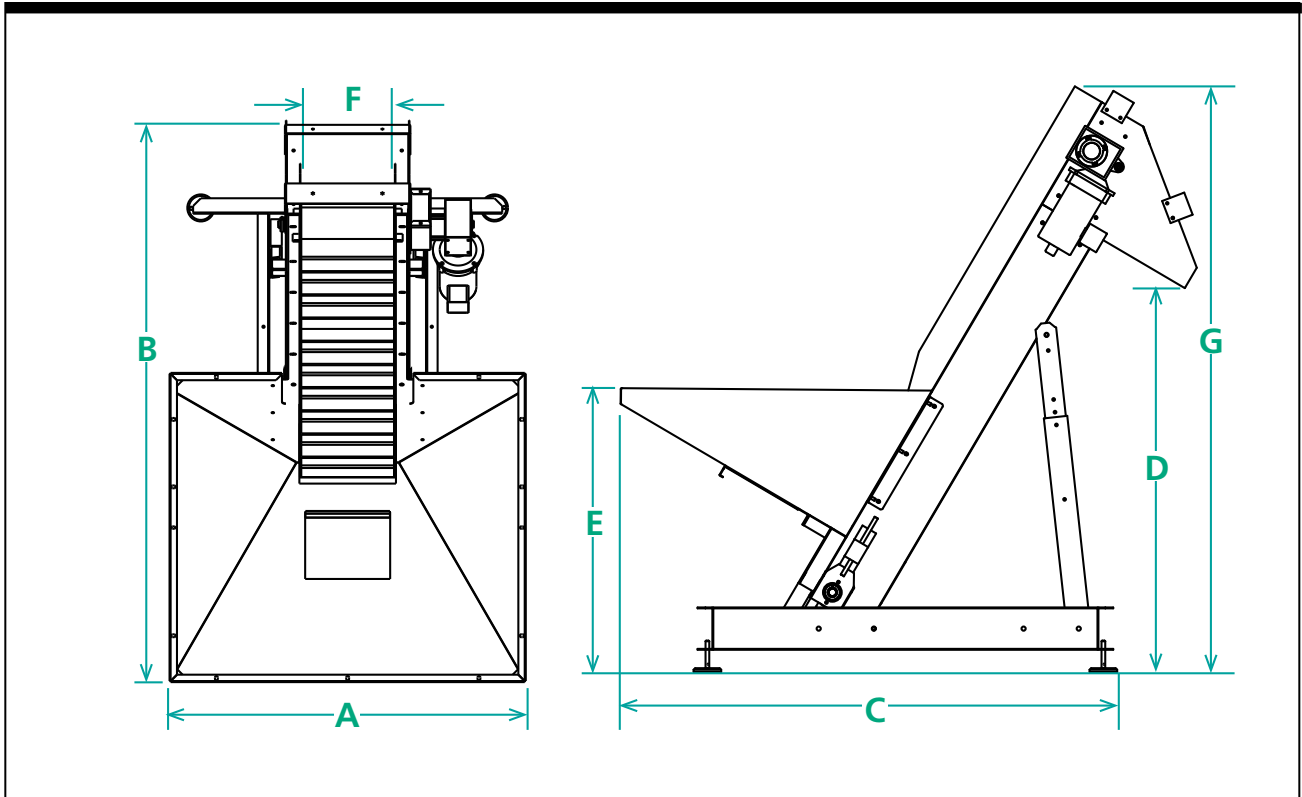

Figure 1-4. EP-10/20/30 Dimension Views

Dimension Specifications		ANSI	Metric
A	Overall Width	46.15"	1172.2mm
B	Overall Length	74.62"	1895.3mm
C	Lower Chassis Footprint	61.86"	1571.2mm
D	Dump Height (Adjustable)	48.88"	1241.6mm
E	Hopper Load Height (EP-10)	38.33"	973.6mm
E	Hopper Load Height (EP-20)	47.33"	1202.2mm
E	Hopper Load Height (EP-30)	56.33"	1430.8mm
F	Belt Width	12.00"	304.8mm
G	Overall Height	77.30"	1963.4mm
Overall Weight		740 lbs.	336kg

Table 1-6. EP-10/20/30 Dimension Specifications

EP-35/EP-50 Elevating Prefeeder Specifications

Standard Features The stainless steel constructed EP-35/50 elevating prefeeders come standard with an FDA/USDA approved white 1-ply solid woven polyester fabric belt, with .156" thick white PVC coating and standard 3.00" tall cleats, and hopper cleanout door.

Optional Features Elevator extensions, hopper extensions, continuous welded hoppers, integrated safety covers, washdown motors, NEMA 1 encased controller, and casters are optional equipment.

Specifications Please refer to the tables below for EP-35/50 specifications:

Specifications	DC	AC
Motor Size	1/2hp	1/2hp
Motor Frame Size	56C	56C
Supply Voltage	90VDC	230/460VAC
Average Belt Speed	23'/min.	7.01 meters/min.
Cleat Height (Nominal)	3.00"	76.2mm
Cleat Pitch	12.00"	304.80mm
EP-35 Hopper Capacity	35 ft ³	991 liters
EP-50 Hopper Capacity	50 ft ³	1416 liters

Table 1-7. EP-35/50 Specifications

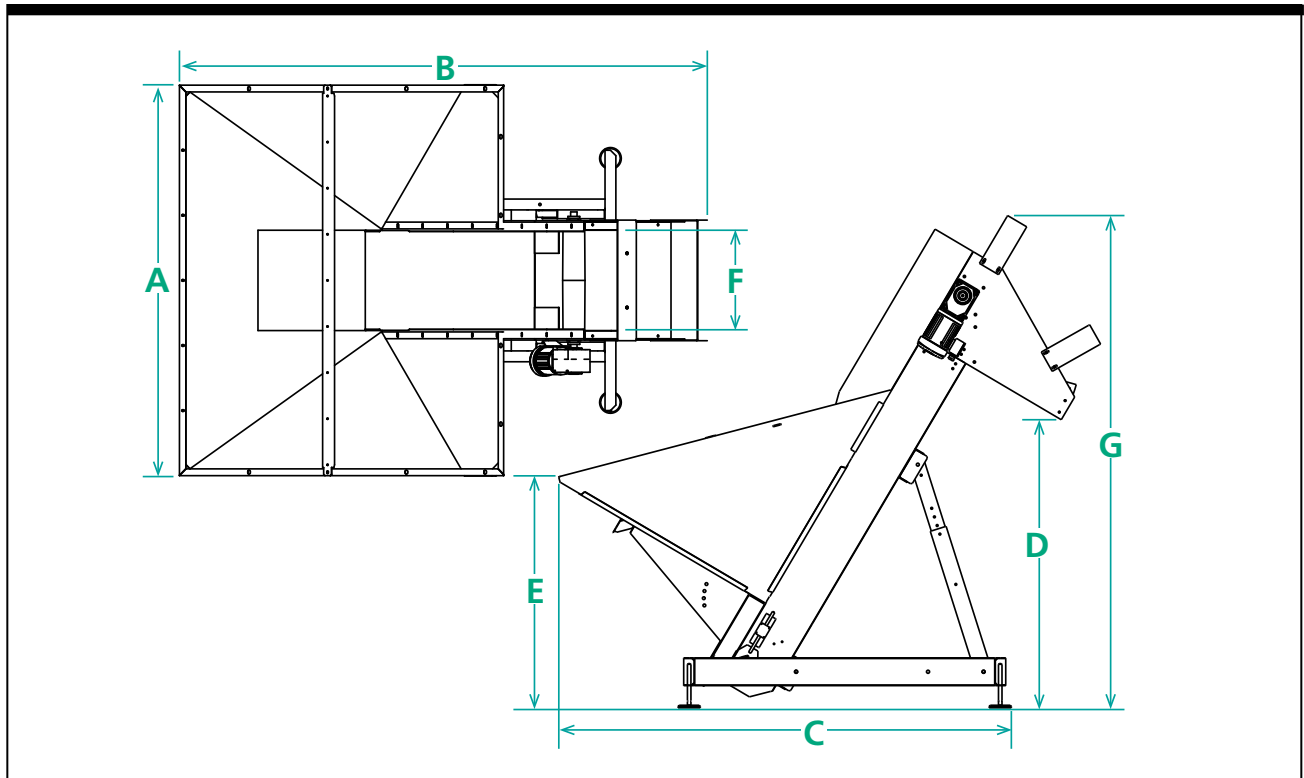

Figure 1-5. EP-35/50 Dimension Views Views

Dimension Specifications		ANSI	Metric
A	Overall Width	72.00"	1828.8mm
B	Overall Length	97.54"	2477.5mm
C	Lower Chassis Footprint	60.00"	1524.0mm
D	Dump Height (Adjustable)	51.87"	1317.5mm
E	Hopper Load Height (EP-35)	41.64"	1057.7mm
E	Hopper Load Height (EP-50)	47.33"	1202.2mm
F	Belt Width	18.00"	457.2mm
G	Overall Height	88.53"	2248.7mm
Overall Weight		1200 lbs.	544 kg

Table 1-8. EP-35/50 Dimension Specifications

Notes

Safety Precautions

2

Safety Precautions

This prefeeder has been designed to be as safe as possible for operators. However, even well-built machines can be installed or operated in a hazardous manner. Safety precautions must be observed by users.

Specific Warnings & Cautions



Turn Power Off! Before servicing the prefeeder, make sure you have turned off compressed air and electrical power in a way that prevents accidental reactivation. Padlock, and clearly tag, the appropriate electrical and pneumatic disconnects. Lockout/Tagout procedures are covered in the United States Code of Federal Regulation (CFR), Title 29, Part 1910.147, "The Control of Hazardous Energy."



Dress Properly. To reduce the risk of injury from moving parts, secure loose clothing. Do not wear jewelry or neckties near the prefeeder. Wear safety glasses or other protective eye wear when operating or performing maintenance on the prefeeder. Never place hands or tools in the prefeeder while it is operating.



Install Safety Covers. Make sure the prefeeder remains safe to operate. Be sure all safety covers have been installed before returning the prefeeder to normal operations. Safety covers on the prefeeder include any covers installed by your direct supplier, as well as standard, permanent guarding.

Operating & Maintenance: Do's & Don'ts



Don't Install the Prefeeder Near Flammable Gas, Vapor or Dust. You must install additional approved explosion-proof or dust-ignition-proof enclosures if installation occurs under these conditions. Without such additional enclosures, normal sparking of the brushes inside the (DC) motor could ignite flammable gas, vapor, or dust.

Do Not Overfill The Hopper. Overfilling the hopper can cause parts to jam inside the hopper, and may damage the prefeeder belt and associated guides.

Do Use the Same or Identical Mounting Screws if Replacing the Motor. If longer mounting screws are used, they may come into contact with parts of the motor that conduct electricity.

Ensure Air is On. Before turning on the system, be sure air is on, or parts may jam. This only applies to systems operating with air.

Do Not Speed Up Prefeeder. Never raise the prefeeder speed to increase the delivery rate. Too many parts in the feeder may prevent it from operating properly.

Avoid Solvents. Do not use solvents for cleaning unless specified, as they may damage surfaces, causing jams or lowered output rates.

Avoid Routine Use of EMERGENCY STOP or E-STOP. Use of EMERGENCY STOP (E-STOP) to shut down the system may cause jams or misoriented parts.

Installation & Start-Up

3

If the Prefeeder is Already Set Up

If you've bought a prefeeder as part of a Shibuya Hoppmann feeder system, then your direct supplier will have performed all the procedures in this chapter. However, you will still need to:

- Position Your Prefeeder.** Follow the equipment layout drawing provided by your direct supplier.
- Connect Electrical Wiring.** Follow as-built electrical diagrams provided by your direct supplier.
- Make Pneumatic Connections.** If your prefeeder has a hopper agitator, your direct supplier will give you setup specifications.
- Install and Test the Rest of the System.** Installation is complete.



Note: If the prefeeder is drop-shipped to your location, follow the procedures in this chapter to finish setting up the prefeeder.

Unpacking and Inspection

Step 1– Inspect and Unpack the Crate. Remove packing materials from sensors, covers, and moving parts. Make a visual check to be sure parts have not come loose during shipping. If you find any concealed damage, call the shipping carrier and your direct supplier immediately. **Do not attempt to fix the problem yourself unless told to do so by your direct supplier.**



Step 2– Record Serial Number of Prefeeder. If you have not already done so, record the prefeeder's model and serial number on the front of this manual. This information is helpful when ordering replacement parts or service.

Shibuya Hoppmann™	
SERIAL # 000XXX	DATE MM/YY
MODEL # EP08/08 WITH 18" EXTENSION BELT	
INVENTORY # EP0808XDSA	
PROJECT NUMBER PRJ000XXXX	
www.shibuyahoppmann.com • (800) 368-3582	

Figure 3-1. Sample Serial Plate

Physical Setup

Step 1—Position the Prefeeder. Place the prefeeder as shown on the equipment layout drawing provided by your direct supplier.

Step 2—Position the Feeder. If you are using a Shibuya Hoppmann Centrifugal Feeder, position the prefeeder so discharged product falls halfway between the center and the inside radius of the bowl (opposite from the point where product loads onto the rim for qualification—refer to Centrifugal Feeder manual). Avoid positioning the prefeeder in a way that allows product to bounce up onto the rim of the bowl and disturb parts that are already oriented. If you are not using a Shibuya Hoppmann Centrifugal Feeder, follow the equipment layout drawing provided by your direct supplier, or the prefeeder may not operate correctly. Level the unit by adjusting the leveling feet and tighten the locknuts.

Step 3—Connect Power and Air. Connect the prefeeder to power and compressed air (if applicable). If your prefeeder has a hopper agitator, your direct supplier will provide you with setup specifications.

Installing Hopper Extensions

Hopper extensions can be added to the EP-04 (to create a 6 ft³ hopper), to the EP-08 (to create either a 15 ft³ or 25 ft³ hopper), the EP-10 (to create either a 20 ft³ or 30 ft³) or the EP-35 (to create a 50 ft³ hopper). When installing hopper extensions, be sure that the prefeeder is powered off, and that the electrical system is tagged out.

Step 1—Remove Any Existing Safety Covers From The Hopper. Keep all the hardware for the safety covers to reinstall the covers once the extension has been installed.

Step 2—Remove Elevator Side Guides Hardware (as necessary). The side guides of the elevator are held in place by hex head screws. Based on the size hopper extension you are

installing, remove the corresponding hardware on the side guides. When you install the extension, you will reuse the same hardware to attach the extension to the side guides.

Step 3—Align New Hopper Extension. The hopper extension is a welded, one-piece unit that fits atop the existing hopper. Align the extension, using the pre drilled holes in the extension and the existing hopper as guides. Once aligned, use the hardware provided with the extension to secure it into place atop the base hopper.

Step 4—Reinstall Side Guide Hardware & Safety Covers.

Reinstall all side guide screws (through new hopper extension holes and side guide holes). Reinstall all safety covers (if necessary).

Installing Elevator Extensions



When adding elevator extensions, the prefeeder's higher center of gravity may cause it to tip. **Before installation, take necessary steps to stabilize the prefeeder. To avoid possible injury, have someone assist you by supporting the head section during removal and installation.**

Step 1—Loosen Take-Up Pulleys and Remove Belt Lacing Pin.

To install an elevator extension to an EP series prefeeder, first

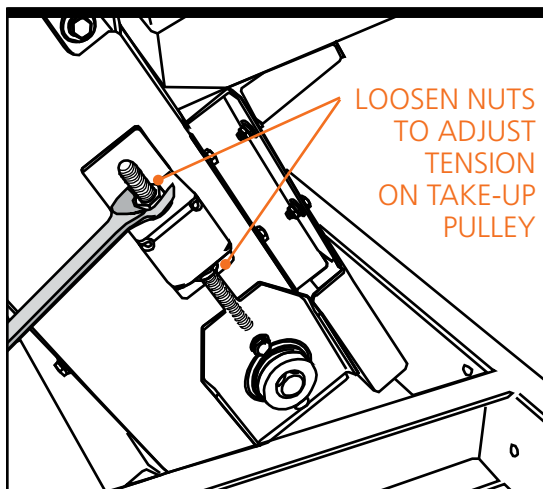

Figure 3-2. Take-Up Pulley

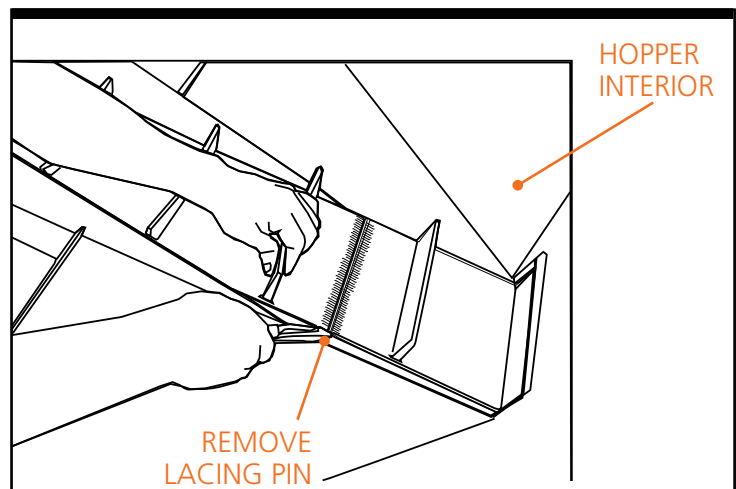

Figure 3-3. Remove Lacing Pin to Remove Belt

rotate the belt so that splice area (location of the lace and pin, see Figure 3-3) are located in the interior of the hopper, just below the side guides. This position will allow easy access to the belt pin for removal. Loosen both sides of the lower pulley take-up brackets (see Figure 3-2). With the belt now loose, remove the belt lace pin. Once the pin has been removed, slide the upper portion of the belt up the elevator channel and out the dump chute of the prefeeder's head. You do not need to remove the belt completely, as it is easier to re-fix the belt once the extension has been added.

Step 2—Disconnect Power and Lockout/Tag Out the Prefeeder. If power has already been supplied to the prefeeder, first lock out and tag out the power supply, then disconnect the wiring to the drive motor (undo the nut at the base of the motor connection box and disconnect wiring - see Figure 3-4).

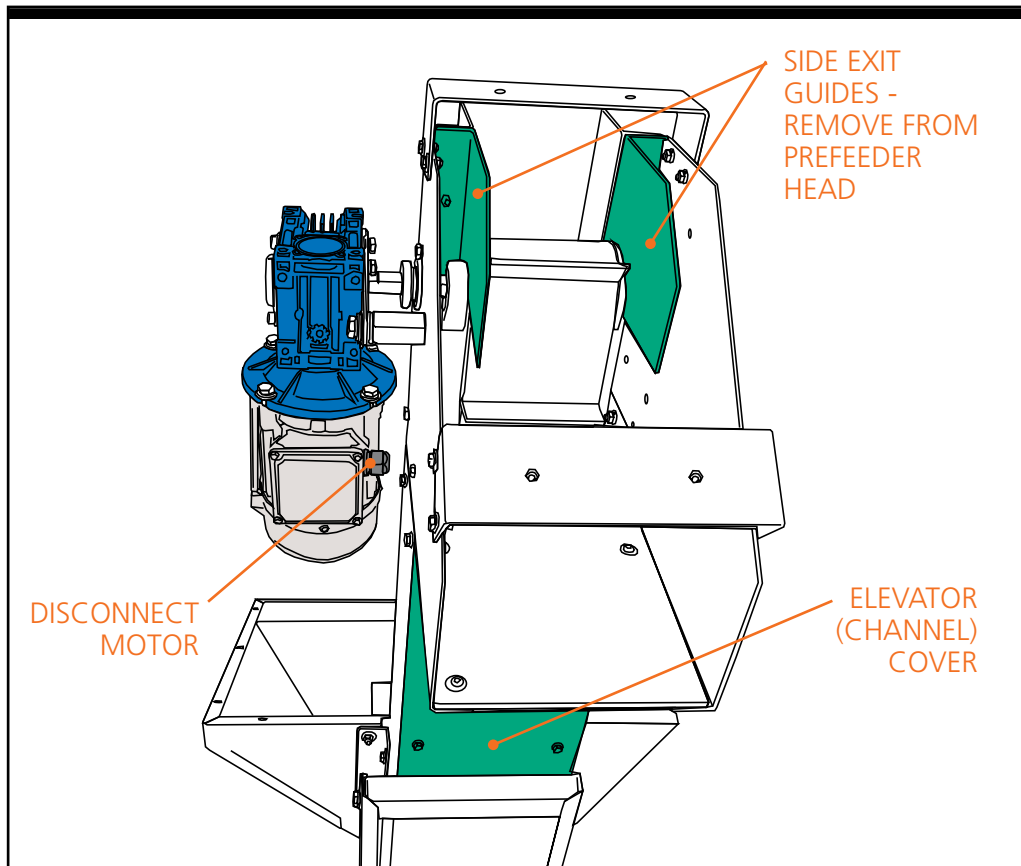

Figure 3-4. Disconnect Power, Remove Elevator Covers, and Remove Head Side Exit Guides

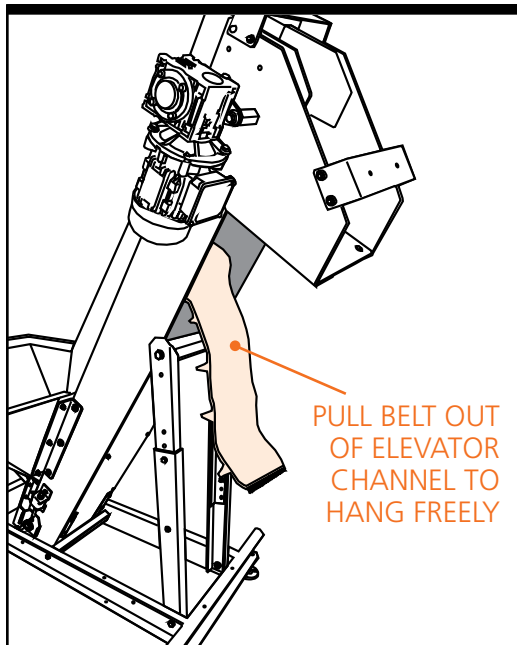

Figure 3-5. Pull Belt Out to Remove Prefeeder Head

Step 3—Remove Channel Cover. Located on the underside of the prefeeder's elevator is a cover over the belt return (Figure 3-4). Undo the four hex bolts that hold the upper cover plate in place, and set the plate aside. Pull the belt down from the prefeeder's head, and let the belt hang (see Figure 3-5).

Step 4—Remove Prefeeder Head. Remove the side guide bolts on the prefeeder head. This frees the two exit guides (left hand and right hand) which help guide the belt. Set these exit guides (see Figure 3-4) to the side. Remove any hardware on the side guides from the head portion of the prefeeder, and set aside. You will not be removing the side guides on the channel, just disconnecting them. Then remove the two bolts on both sides of the prefeeder channel or neck (see Figure 3-6) and set aside.

The head of the prefeeder (with the drive motor assembly) should be supported during this removal process. Guide the head up and off the neck of the prefeeder, allowing the belt to slide through the chute area, remaining "attached" to the prefeeder. Set the head to the side.

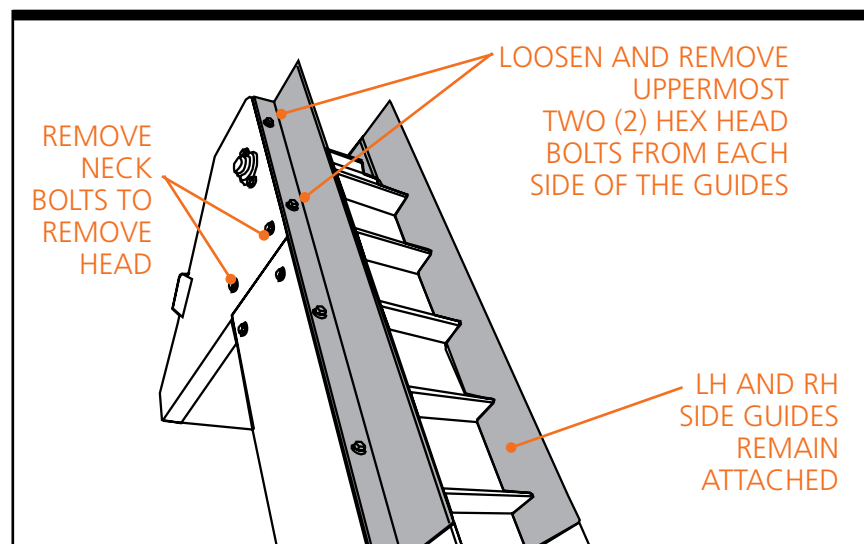

Figure 3-6. Side Guides - Remove Hardware

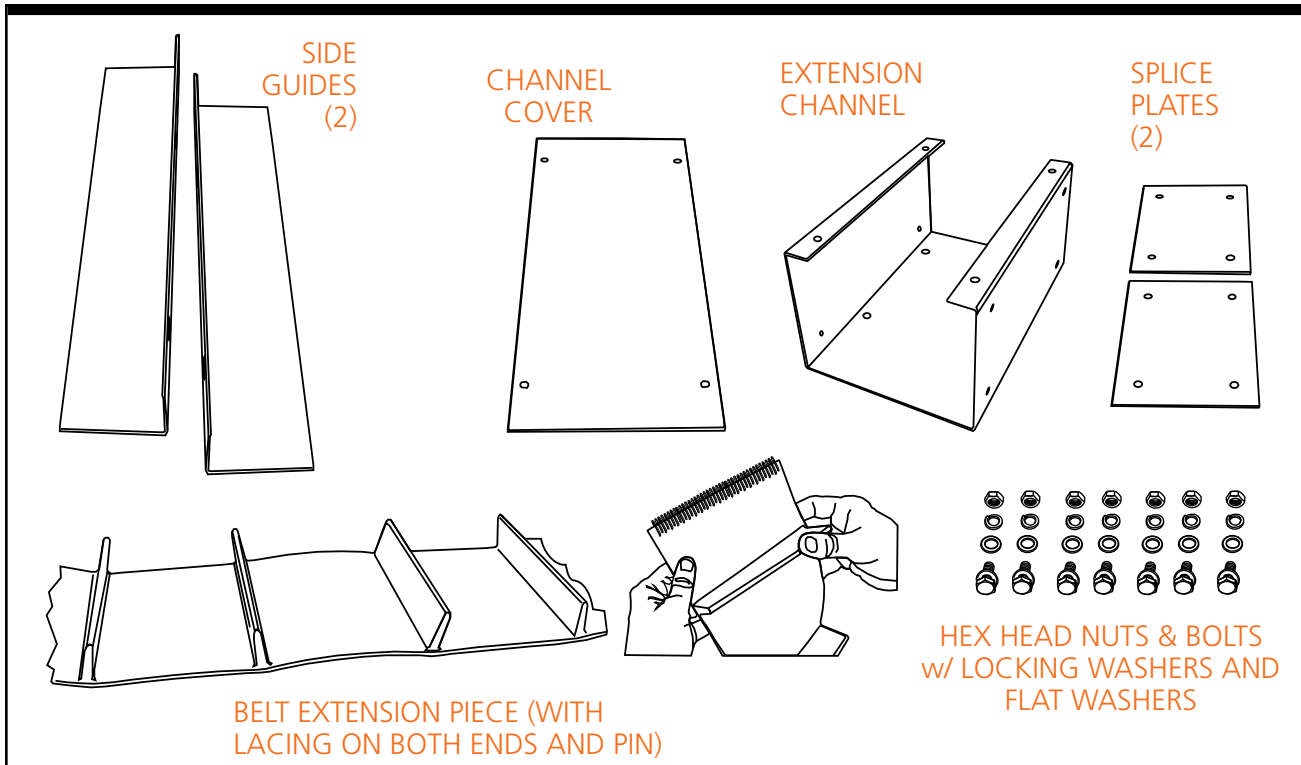

Figure 3-7. Extension Kit for Prefeeder Extension

Step 5—Inventory the Elevator Extension Kit. The extension kit will include the following: Channel Extension (1), Side Guide Extension (2), Splice Plates (2), Channel Cover (1), associated hardware, and Belt Extension (see Figure 3-7 above).

Step 6—Install Extension. Attach the splice plates to the extension channel (inside), hand-tightening the bolts prior to installing the extension on the prefeeder. Then lift the extension up slide it onto the prefeeder neck, securing it with hand-tightened hex head bolts (2). Before tightening the bolts, align the seams of the existing channel and the new extension as closely as possible. Tighten the extension channel bolts and splice plate bolts at this time.

Step 7—Re-Install the Prefeeder Head. Reinstall the head of the prefeeder over the new extension, aligning the head's splice plates with the holes on the extended neck. Hand tighten the bolts, then tighten them once the pieces are aligned.

Step 8–Re-Install LH/RH Exit Guides and New Side Guides.

Replace the left hand and right hand exit guides (removed in Step 4) and align the new side guide extensions along the channel, using the holes provided in the channel. Once aligned, attach with the new hardware (Figure 3-7).

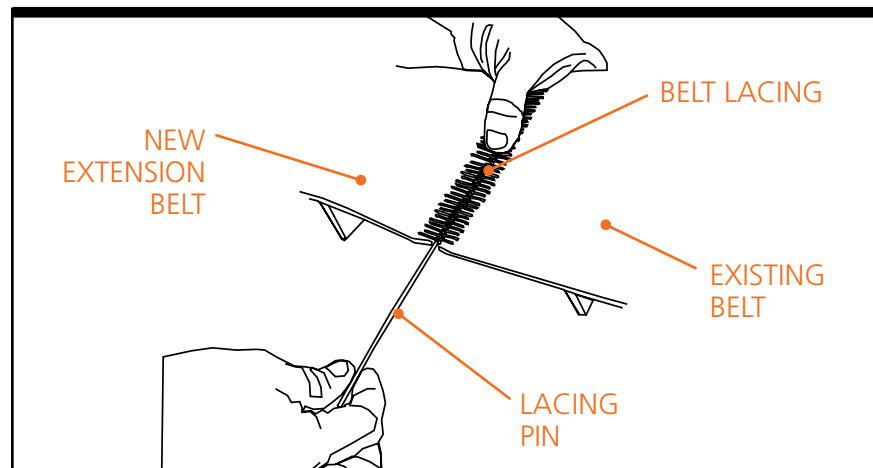

Figure 3-8. Attach New Belt Extension to Existing Belt

Step 9–Attach New Belt Extension. Both ends of the new extension belt are laced. Attach one end of the belt extension to the part of the belt hanging out of the prefeeder's channel (Figure 3-5), using the lacing pin to lock both ends together (Figure 3-8). Feed the belt back through the neck of the prefeeder and through the head, letting it flow down the elevator of the prefeeder towards the hopper. Attach the other end of the belt extension to the end of the belt rising up from the base of the hopper. Retighten the take-up pulley to apply some tension to the belt (refer to Step 12 for more information on tracking/adjusting your belt).

Step 10–Install the Elevator Covers. Reinstall the elevator cover and the new elevator cover extension on the underside of the prefeeder.

Step 11–Reconnect Power. Restore power to the motor.

Step 12—Adjust Tracking. Turn the prefeeder on and set to a slow speed to observe tracking of the belt. Run a new belt at least several complete revolutions before adjusting the tracking. If the belt pulls to one side or if the belt moves from side to side, adjust the tensioner bracket on the side to which the belt is pulling (see Figure 3-9).

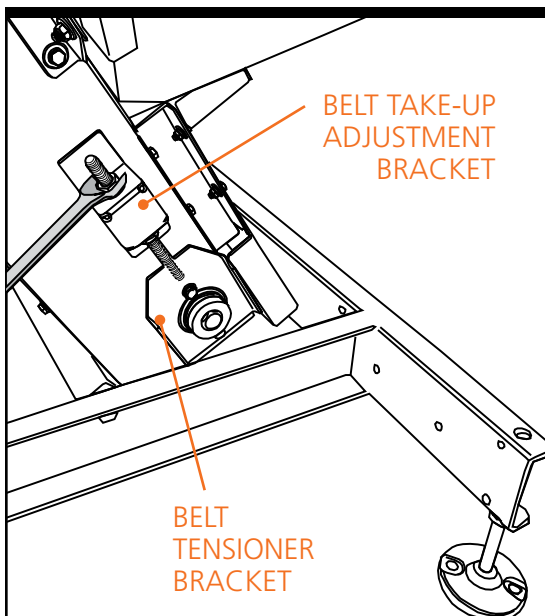

Figure 3-9. Tracking Adjustment of Belt Made to Belt Tensioner



Do not overtighten the belt. The elevator extensions added call for greater slack in the belt. This is normal, and should not be adjusted by overcompensating for the slack. You may apply too much tension and destroy the belt lacing. For more information on belt tracking, refer to "Installing Belts and Belt Extensions" further in this chapter.

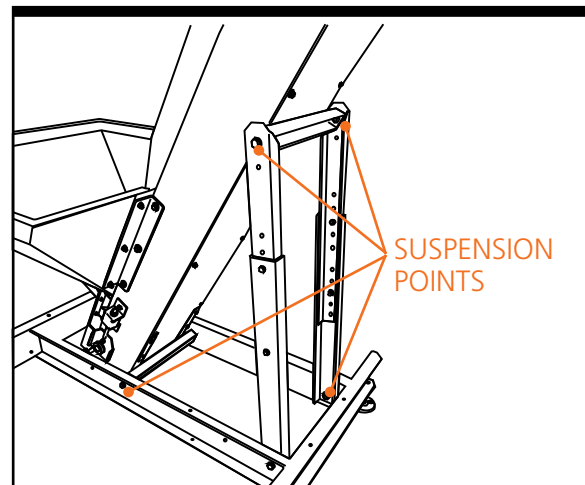

Figure 3-10. Adjusting the Dump Height Suspension Points

Step 13—Adjust Dump Heights. Once the extension is installed, you may need to adjust the dump height by more than the leveling feet will allow. To adjust the dump height of the prefeeder, loosen the six suspension points which connect the elevator and front legs to the frame of the prefeeder on both sides (see Figure 3-10). This allows the unit to pivot when adjusting the dump height once the two bolts in the telescoping portion

of the legs are removed. The elevator portion of the prefeeder must be supported by other means any times the legs are to be adjusted! Then, raise or lower the height of the front legs by changing the holes in which the legs connect to the frame. Extra holes are provided to move the legs up or down. When the desired dump height is achieved, replace the bolts and tighten the locknuts in the front legs and the six suspension points to secure the prefeeder. The chart below indicates the recommended dump heights and dump height specifications.

Dump Height Reference Chart			
Prefeeder Model	Part Number	Length of Extension	Dump Height*
EP - 04/06	N/A	Standard height	42"
	EX18EP04SU	18" Extension	58"
	EX24EP04SU	24" Extension	63"
	EX36EP04SU	36" Extension	73"
	EX54EP04SU	54" Extension	89"
EP - 08/15/25	N/A	Standard height	48"
	EX18EP08SU	18" Extension	64"
	EX36EP08SU	36" Extension	79"
	EX54EP08SU	54" Extension	95"
EP - 10/20/30	N/A	Standard height	48"
	EX18EP10SU	18" Extension	64"
	EX36EP10SU	36" Extension	79"
	EX54EP10SU	54" Extension	95"
EP - 35/50	N/A	Standard height	48"
	EX18EP35SU	18" Extension	64"
	EX36EP35SU	36" Extension	79"
	EX54EP35SU	54" Extension	95"

Table 3-1. Dump Height Reference Chart



It is strongly recommended that the frame of the prefeeder be reinforced and/or additionally supported, when the elevator extensions are more than 36" for an EP-04/06, or more than 54" for an EP-08, EP-10 or EP-35 Series.

A base extension support kit may be purchased from Shibuya Hoppmann Corporation, however, they may need to be customized for your prefeeder. Please contact Shibuya Hoppmann Corporation for additional information on this frame base kit.

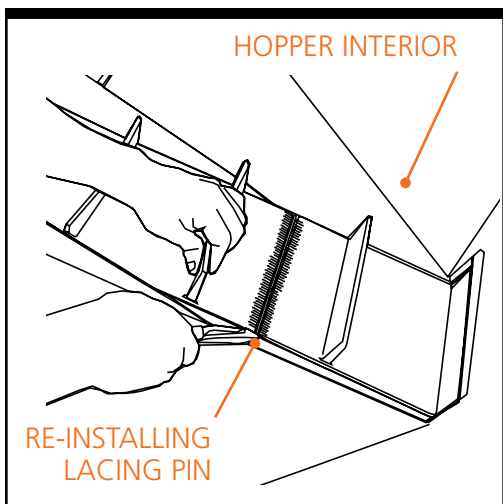

Figure 3-11. Re-Installing Lacing Pin

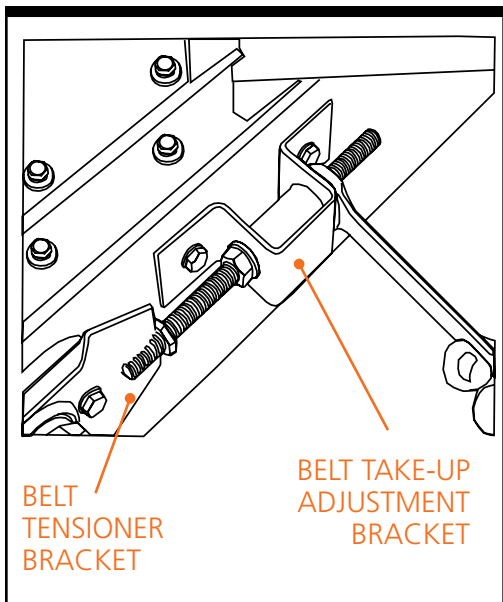

Figure 3-12. Tracking Adjustment of Belt Made to Belt Tensioner

Replacing/Installing Belts and Extensions

Step 1–Disconnect Power and Lockout/Tag Out the Prefeeder. Lockout and tag out any power supply to the prefeeder.

Step 2–Install Belt. Install the belt by feeding it through the prefeeder's hopper (downward), up the underside of the elevator channel, through the head, and back down the elevator channel into the hopper, cleats facing up. The belt lacings on both ends of the belt, should meet in the hopper area of the prefeeder (see Figure 3-11). You may need to remove the elevator covers (underside of the prefeeder channel) to feed the belt. Once the belt is completely fed into the prefeeder, and the lacing pin installed, replace the elevator covers.

Step 3–Tension Belt. Use the tensioner brackets on the base of the prefeeder (see Figure 3-12) to remove excessive slack in the belt before beginning tracking.



Do not overtighten the belt. When tightening the take-up pulley, apply minimum tension necessary to take up slack and properly track the belt. If you apply too much tension, you can easily destroy the belt lacing or decrease the life of the pulley bearings.

One Piece Belt Replacement Chart (Part Number and Length)			
Prefeeder Model	Part Number	Length of Extension	Extension Belt Length
EP - 04/06	BELTEP4126	Standard	126"
	BELTEP4162	18" Extension	162"
	BELTEP4174	24" Extension	174"
	BELTEP4198	36" Extension	198"
	BELTEP4234	54" Extension	234"
EP - 08/15/25	BELTEP8144	Standard	144"
	BELTEP8180	18" Extension	180"
	BELTEP8216	36" Extension	216"
	BELTEP8252	54" Extension	252"
EP - 10/20/30	BELTEP10144	Standard	144"
	BELTEP10180	18" Extension	180"
	BELTEP10216	36" Extension	216"
	BELTEP10252	54" Extension	252"
EP - 35/50	BELTEP35168	Standard	168"
	BELTEP35204	18" Extension	204"
	BELTEP35240	36" Extension	240"
	BELTEP35276	54" Extension	276"

Table 3-2. One Piece Extension - Belt Replacement

Step 4–Turn on Power and Adjust Tracking. Restore power to the prefeeder and turn it on, setting it to a slow speed to observe tracking of the belt. Run a new belt at least several complete revolutions before adjusting the tracking. If the belt pulls to one side or if the belt moves from side to side, adjust the tensioner bracket on the side to which the belt is pulling (see Figure 3-12.)

Step 5–Adjust Tracking Again. Run the prefeeder for at least five (5) minutes. Continue to adjust tracking until the prefeeder runs consistently without tracking problems.

Step 6–Adjust Tensioning. A properly tensioned belt will not slip with a hopper full of product. To avoid injury, turn off the

Replacement Belts - Extension Belt Piece Only - Reference Chart			
Prefeeder Model	Description	Part Number	Extension Belt Length
EP - 04/06	18" Extension	BELTEP4036	36"
	24" Extension	BELTEP4048	48"
	36" Extension	BELTEP4072	72"
	54" Extension	BELTEP4108	108"
EP - 08/15/25	18" Extension	BELTEP8036	36"
	36" Extension	BELTEP8072	72"
	54" Extension	BELTEP8108	108"
EP - 10/20/30	18" Extension	BELTEP10036	36"
	36" Extension	BELTEP10072	72"
	54" Extension	BELTEP10108	108"
EP - 35/50	18" Extension	BELTEP35036	36"
	36" Extension	BELTEP35072	72"
	54" Extension	BELTEP35108	108"

Table 3-3. Extension Only - Belt Replacement

prefeeder before checking tension. Tighten or loosen the tension equally to ensure proper tension. Tighten the locknuts of the tension rod.



Do not set tools where they can fall into the hopper or any moving parts.



Do not overtighten the belt. The elevator extensions added call for greater slack in the belt. This is normal, and should not be adjusted by overcompensating for the slack. You may apply too much tension and destroy the belt lacing.

Level Sensor

The most common method of controlling the prefeeder is with a level sensing device. This device monitors the down stream equipment and tells the prefeeder when to supply product by

activating the motor on the prefeeder for a duration of time. The sensor keeps the level of product, from the prefeeder to the equipment, relatively constant by controlling the amount of product metered into the receiving equipment. For further information contact Shibuya Hoppmann Corporation, or your direct supplier.

Establishing the Correct Prefeeder Speed

The speed of the prefeeder should be set so that the minimum amount of product is in the feeder (or other equipment), and the required rate is still obtained. You may have to adjust the settings, and count product to find the optimum speed.

Wiring Schematics

The wiring schematic for prefeeders with AC drives is show in Figure 3-13. The following page shows the DC wiring diagram for the EP Series elevating prefeeders.

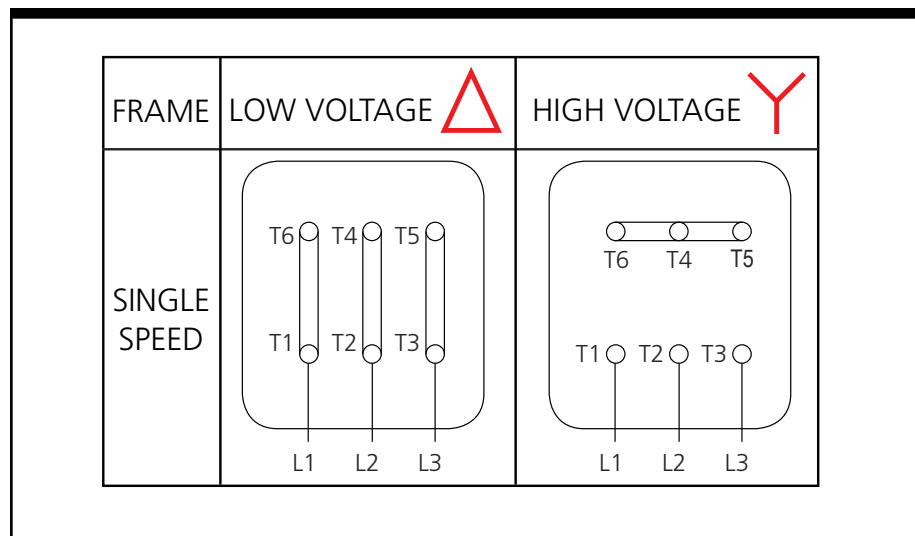

Figure 3-13. Wiring Diagram - AC Prefeeder

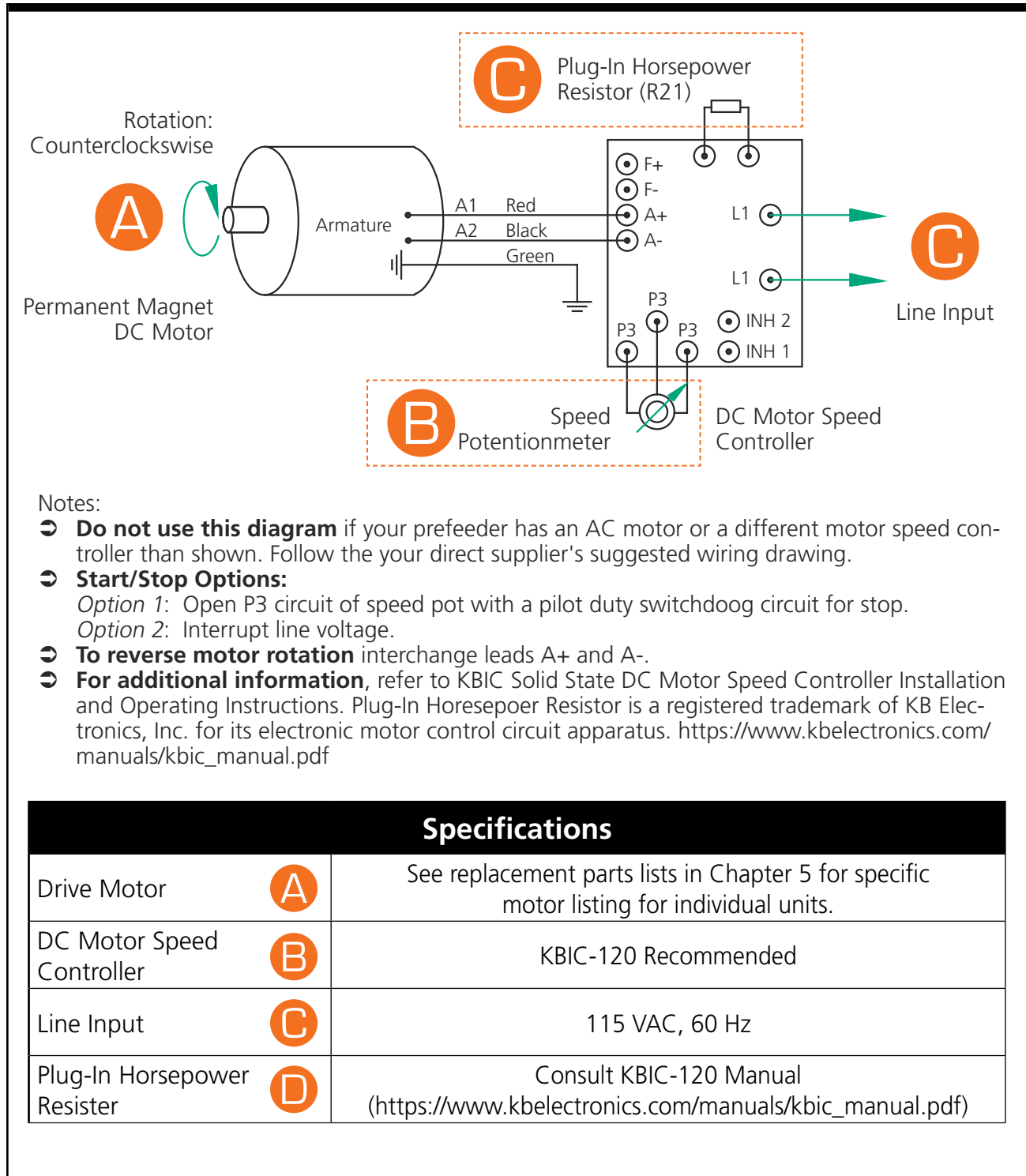

Figure 3-14. Wiring Diagram - DC Prefeeder

Preventive Maintenance

4

Upper Drive Pulley

The main components of the upper drive pulley assembly are a drive motor and gear reducer, a drive coupling and a pair of flanged bearings. Each bearing assembly consists of a bearing insert (bearing plus a clamp collar) and a pair of bearing flanges. Refer to Figure 4-1 for part description. The bearing inserts are lubrication free. If a bearing requires replacement, the bearing flanges can be reused if they appear unworn and undamaged.

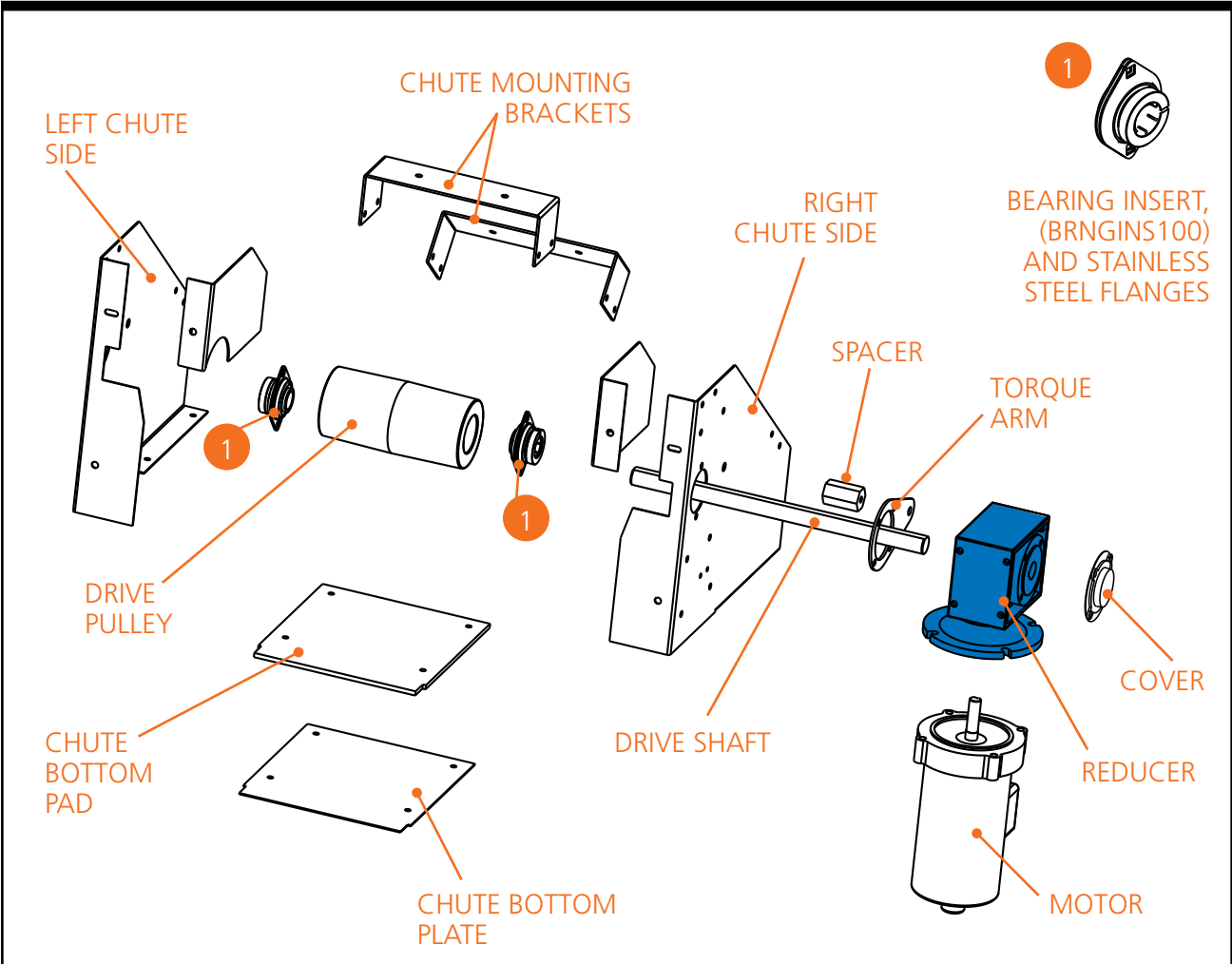

Figure 4-1. Drive Pulley (Head) with Motor/Reducer Sub-Assembly (DC Motor Shown)

Lower Take-Up Pulley

The main components of the lower take-up pulley assembly consist of two belt tensioner brackets, a take-up shaft, two bearing assemblies and a drive pulley (see Figure 4-2). Like the drive pulley bearings, each bearing assembly consists of a bearing insert (bearing plus a clamp collar) and a pair of bearing flanges. The bearing inserts are lubrication free. If a bearing requires replacement, the bearing flanges can be reused if they appear unworn and undamaged.

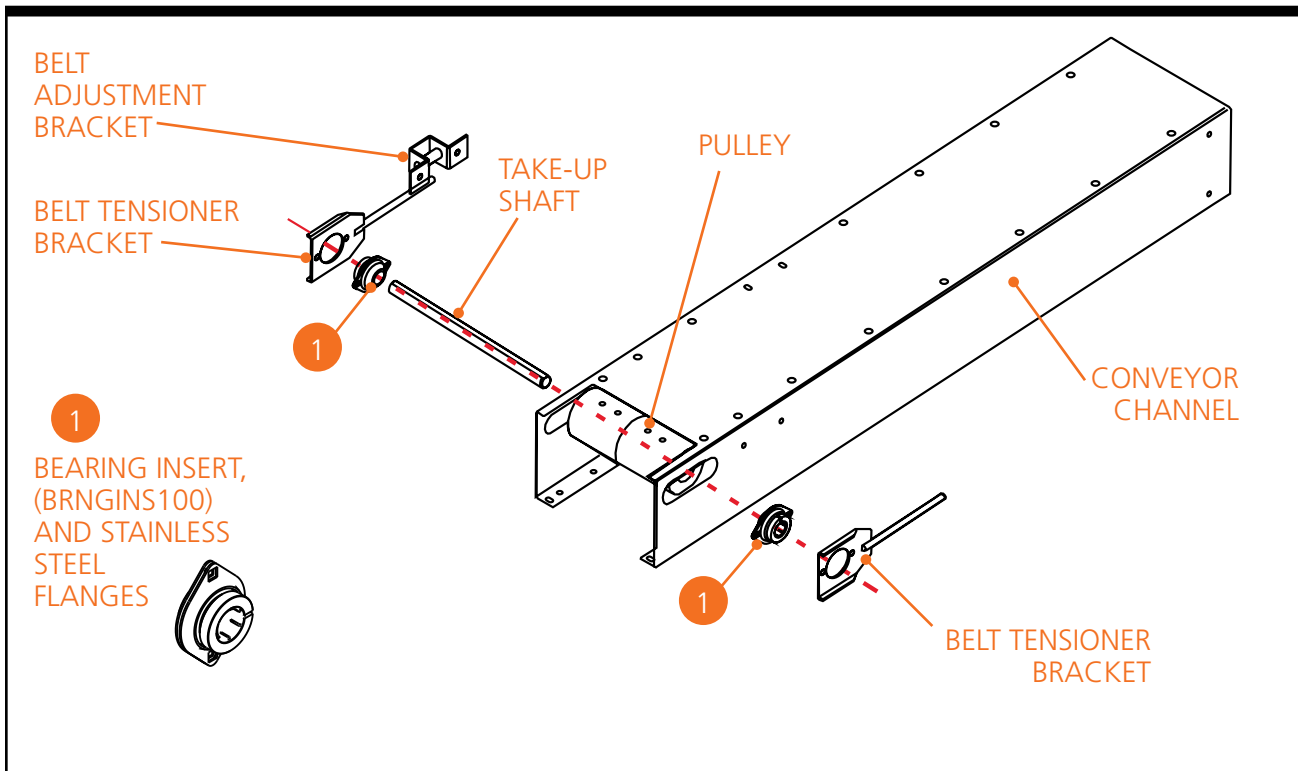

Figure 4-2. Lower Take-Up Pulley Sub-Assembly

Reducers

The reducers are lubricated for life and maintenance free.

Routine Cleaning

When necessary, clean the belt surface with a cloth dampened with water, or you can use a mild household cleaner. Wipe off damp surfaces with a dry, clean cloth.

The entire prefeeder can be wiped down with a clean cloth, and stainless steel cleaner may be used if needed. Do not use any type of abrasive cleanser on the equipment.

Notes

Replacement Parts

5

Replacement Parts

Replacement parts lists for the Hoppmann prefeeders are listed on the following pages. When ordering replacement parts, please reference the model name and number of your feeder located on the serial plate (see Figure 5-1). This helps in making sure you receive the correct replacement parts.

If you received a customized Shibuya Hoppmann system, please refer to your system's Operation Manual when ordering spares, as your prefeeder may have been altered.

Having the serial number in addition to the part number you wish to order will help us to accurately assist you in getting the correct parts. You may order your prefeeder's spare parts directly from Shibuya Hoppmann by email, phone or fax (see the contact information listed below).

Shibuya Hoppmann Spares and Service Department

- **Email:** Spares@Hoppmann.com
- **Phone:** 434.929.4746 (1.800.368.3582)
- **Fax:** 434.929.4959
- **Mail:** Shibuya Hoppmann Corporation
Attn: Spares Department
291 Dillard Road, P.O. Box 879
Madison Heights, VA 24572 USA
www.ShibuyaHoppmann.com

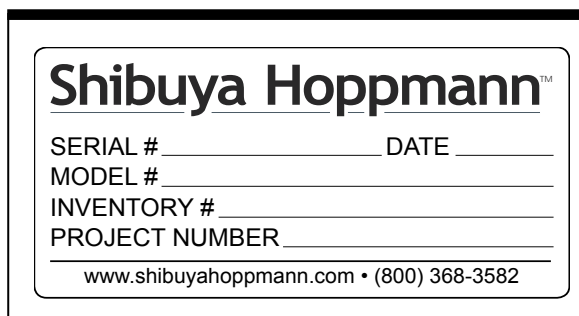

Figure 5-1. Sample Serial Plate

Notes: Occasional product serial numbers will be preceded by a "V" or "C", which indicates the equipment has been customized for you specifically. When calling for parts, be sure to indicate if your equipment has this configuration (example: VEP0808XASA or CEP0406XDSA).

EP-04/06 Prefeeder Replacement Parts

Part Number	Description	Qty.
MOTRP.25HP	1/4hp DC Motor, 90VDC	1
NMRV500040	Speed Reducer, 40:1	1
MOTRAC0025-M	1/4hp AC Motor, 208-230/460VAC, 60Hz	1
PULLCNVEP4	Pulley, EP04, F.G.	2
EP04000006	Drive Shaft, EP-04 w/Torque Arm	1
EP04000003	EP04 Take-Up Shaft, 1" O.D.	1
FLNGSS1/25	25mm Stainless Steel Flange	8
BRNGINS100	Bearing Insert, ANSI, 1.0"	4
EP350300	Belt Tensioner Bracket	2
FOOTM12100	Level Foot, M12 x 100mm Long Stainless Steel	4
EP04000005	Chute, Bottom Pad	1
BELTEP4126	Standard EP-04/06 Belt, 126" Long	1
BELTEP4162	Belt, EP-04/06 with 18" Extension, 162" Long	1
BELTEP4174	Belt, EP-04/06 with 24" Extension, 174" Long	1
BELTEP4198	Belt, EP-04/06 with 36" Extension, 198" Long	1
BELTEP4234	Belt, EP-04/06 with 54" Extension, 234" Long	1

* Check your original equipment for extensions added to your prefeeder before ordering belts.

EP-04/06 Washdown Prefeeder Replacement Parts

Part Number	Description	Qty.
NMRV300040	Speed Reducer, 40:1	1
MOTRPMWD14	1/4hp DC Motor, Washdown, 90VDC	1
MOTRACWD25	1/4hp AC Motor, 60Hz, Washdown	1
PULLCNVEP4	Pulley, EP04, F.G.	2
EP04SM0012	Drive Shaft, Stainless Steel	1
EP04FG0100	Coupling Assembly, Nickel Plated	1
SK12406-2	Output Shaft, Stainless Steel	1
FLNGSS1/25	25mm Stainless Steel Flange	8
BRNGINSM02	Bearing Assembly, Stainless Steel, 25mm	4
EP350300	Belt Tensioner Bracket	2
EP04SM0013	Take-Up Shaft, Stainless Steel	2
FOOTM12100	Level Foot, M12 x 100mm Long Stainless Steel	4
EP04000005	Chute, Bottom Pad	1
BELTEP4126	Standard EP-04/06 Belt, 126" Long *	1
BELTEP4162	Belt, EP-04/06 with 18" Extension, 162" Long	1
BELTEP4174	Belt, EP-04/06 with 24" Extension, 174" Long	1
BELTEP4198	Belt, EP-04/06 with 36" Extension, 198" Long	1
BELTEP4234	Belt, EP-04/06 with 54" Extension, 234" Long	1

* Check your original equipment for extensions added to your prefeeder before ordering belts.

EP-08/15/25 Prefeeder Replacement Parts

Part Number	Description	Qty.
NMRV500040	Speed Reducer, 40:1, 56C (Option)	1
MOTRP.25HP	1/4hp DC Motor, 90VDC, 56C	1
MOTRAC0025-M	1/4hp AC Motor, 208-230/460VAC, 60Hz	1
PULLCNVEP8	Drive Pulley, EP-08 Standard, FG	2
EP12000015	Drive Shaft, EP-08, W/Torque Arm	1
EP08000010	EP-08 Take up Shaft, 1" OD	1
FLNGSS1/25	25mm Stainless Steel Flange	8
BRNGINS100	Bearing Insert, ANSI, 1.0"	4
EP350300	Belt Tensioner Bracket	1
FOOTM12100	Level Foot, M12 x 100mm Long Stainless Steel	4
EP80026	Chute Bottom Pad	1
BELTEP8144	Standard EP-08/15/25 Belt, 144" Long*	1
BELTEP8180	Belt, EP-08/15/25 with 18" Extension, 180" Long	1
BELTEP8216	Belt, EP-08/15/25 with 36" Extension, 216" Long	1
BELTEP8252	Belt, EP-08/15/25 with 54" Extension, 252" Long	1

* Check your original equipment for extensions added to your prefeeder before ordering belts.

EP-08/15/25 Washdown Prefeeder Replacement Parts

Part Number	Description	Qty.
NMRV500040	Speed Reducer, 40:1, 56C (Option)	1
MOTRPMWD14	1/4hp DC Motor, Washdown, 90VDC	1
MOTRACWD33	1/3hp AC Motor, Washdown, 208-230/460VAC, 60Hz	1
PULLCNVEP8	Drive Pulley, EP-08 Standard, FG	2
EP12000015	Drive Shaft, EP-08 with Torque Arm	1
BRNGINSSS1	Bearing Insert, 1" Stainless Steel	1
EP08000010	EP-08 Take-Up Shaft	1
FLNGSS1/25	25mm Stainless Steel Flange	8
EP350300	Belt Tensioner Bracket	2
FOOTM12100	Level Foot, M12 x 100mm Long Stainless Steel	4
BELTEP8144	Standard EP-08/15/25 Belt, 144" Long *	1
BELTEP8180	Belt, EP-08/15/25 with 18" Extension, 180" Long	1
BELTEP8216	Belt, EP-08/15/25 with 36" Extension, 216" Long	1
BELTEP8252	Belt, EP-08/15/25 with 54" Extension, 252" Long	1

* Check your original equipment for extensions added to your prefeeder before ordering belts.

EP-10/20/30 Prefeeder Replacement Parts		
Part Number	Description	Qty.
NMRV500040	Speed Reducer, 40:1, 56C	1
MOTRP.25HP	1/4hp DC Motor, 90VDC	1
MOTRAC0025-M	1/4hp AC Motor, 208-230/460, 60Hz	1
PULLCNVEP10	Drive Pulley, EP-10 Standard, FG	2
EP12000014	Drive Shaft, EP-10/12, W/Torque Arm	1
FLNGSS1/25	25mm Stainless Steel Flange	8
BRNGINS100	Bearing Insert, ANSI, 1.0"	4
EP350300	Belt Tensioner Bracket	1
EP12000013	Take-Up Shaft	1
FOOTM12100	Level Foot, M12 x 100mm Long Stainless Steel	4
BELTEP10144	Standard EP-10/20/30 Belt, 144" Long	1
BELTEP10180	Belt, EP-10/20/30 with 18" Extension, 180" Long	1
BELTEP10216	Belt, EP-10/20/30 with 36" Extension, 216" Long	1
BELTEP10252	Belt, EP-10/20/30 with 54" Extension, 252" Long	1

** Check your original equipment for extensions added to your prefeeder before ordering belts.*

EP-35/50 Prefeeder Replacement Parts

Part Number	Description	Qty.
NMRV500050	Speed Reducer, 50:1, 56C	1
MOTRPM0102	1/2hp DC Motor, 90VDC	1
MOTRAC0050-M	1/2hp AC Motor, 230/460VAC, 60Hz	1
PULLCNVEP35	EP-35 Pulley, UHMW	2
EP35S0014T	Drive Shaft, EP-35 w/Torque Arm	1
FLNGSS1/25	25mm SS Flange	8
BRNGINS100	Bearing Insert, ANSI, 1.0"	4
EP350300	Belt Tensioner Bracket	1
EP35S010	Tail Pulley (Take-Up) Shaft	1
FOOTM16180	Level Foot, M16 x 180mm Long Stainless Steel	4
BELTEP35168	Standard EP-35/50 Belt, 168" Long	1
BELTEP35204	Belt, EP-35/50 with 18" Extension, 204" Long	1
BELTEP35240	Belt, EP-35/50 with 36" Extension, 240" Long	1
BELTEP35276	Belt, EP-35/50 with 54" Extension, 276" Long	1

* Check your original equipment for extensions added to your prefeeder before ordering belts.

Notes

Warranty

6

Warranty

Shibuya Hoppmann Corporation warrants that each item of its own manufacture delivered hereunder shall, at the time of delivery and for a period of twelve (12) months thereafter, be free from defects in materials or workmanship; and if any such item shall prove to be defective in material or workmanship under normal intended usage and maintenance during the warranty period, upon examination by Shibuya Hoppmann Corporation, then Shibuya Hoppmann Corporation shall repair or replace, at its sole option, such defective item at its own expense; provided, however, that the owner shall be required to ship such defective item, freight prepaid, to Shibuya Hoppmann Corporation's plant in Virginia. The warranty on components not manufactured by Shibuya Hoppmann Corporation, but a part of the feeder, is limited to the warranty provided by the original manufacturer of said components to the extent, and only to the extent, that such original manufacturer actually honors such warranty.

ALL WARRANTIES HEREUNDER ARE EXPRESSLY LIMITED TO THE REPAIR OR REPLACEMENT OF DEFECTIVE ITEMS AS SET FORTH HEREIN, AND IN NO EVENT SHALL SHIBUYA HOPPMANN CORPORATION BE LIABLE FOR SPECIAL, INCIDENTAL OR CONSEQUENTIAL DAMAGES BY REASON OF ANY BREACH OF WARRANTY OR DEFECT IN MATERIAL OR WORKMANSHIP. SHIBUYA HOPPMANN CORPORATION SHALL NOT BE RESPONSIBLE FOR REPAIR OR REPLACEMENT OF ITEMS WHICH HAVE BEEN SUBJECTED TO NEGLIGENCE, ACCIDENT OR IMPROPER USE, OR WHICH HAVE BEEN ALTERED BY OTHER THAN AUTHORIZED SHIBUYA HOPPMANN CORPORATION PERSONNEL.

THIS WARRANTY IS IN LIEU OF OTHER WARRANTIES, EXPRESS OR IMPLIED. ALL IMPLIED WARRANTIES, INCLUDING BUT NOT LIMITED TO THE IMPLIED WARRANTIES OF MERCHANTABILITY AND FITNESS FOR A PARTICULAR PURPOSE, ARE HEREBY EXCLUDED.

Shibuya Hoppmann™

Shibuya Hoppmann offers a wide selection of products:

- ➔ Prefeeder/Centrifugal Parts
- ➔ Feeders/Unscramblers
- ➔ Filler/Plugger/Capper Systems (CIP/SIP)
- ➔ Pharmaceutical/Beverage Filling Systems for:
 - Liquid
 - Powder
 - Aseptic
 - Non-Aseptic
- ➔ Multi Part Assembly Systems
 - Continuous Motion
 - Indexing/Intermittent
- ➔ Capping Systems – Servo or Mechanical
- ➔ Placement Systems
- ➔ Rotary/Inline Pressure Sensitive Labelers
- ➔ Print and Apply Labelers
- ➔ I.V. Bag Form/Fill/Seal Systems
- ➔ Pouch Fill/Cap/Seal Systems
- ➔ Collating Systems
- ➔ Puck Feed/Loading and Unloading Systems
- ➔ Syringe Filling/Assembly Systems
- ➔ Electron Beam Aseptic Filling Systems
- ➔ Line Integration/Validation Services
- ➔ PMMI Certified Training

Headquarters

7849 Coppermine Drive
Manassas, VA
20109
540.829.2564 t
800.368.3582 t
540.829.1726 f

Sales

1445 Brookville Way
Suite F
Indianapolis, IN 46239
317.322.0754 t
800.368.3582 t
317.322.0794 f

Manufacturing

291 Dillard Road
Madison Heights, VA
24572
434.929.4746 t
800.368.3582 t
434.929.4959 f

