

EH-35/50 Horizontal Discharge Elevating Prefeeder



Product Overview:

The EH-35/50 horizontal discharge, elevating prefeeder is designed to handle medium-sized parts. Using a modular, plastic, cleated chain to vertically and horizontally transport parts, this prefeeder allows the discharge to be closer to the bowl, eliminating potential scuffing or scraping of parts while being able to reach over existing equipment. A heavy duty variable speed motor helps to ensure proper product metering. Note: Controllers and mechanical level sensors are not supplied with this unit.

Part Number	EH3518XDSA	EH3518XASA
Motor Style	DC	AC
Motor Voltage	90V	230/460V
Horsepower	1/3hp	1/3hp
Hopper Capacity (EH-35/EH-50)	35 ft ³ – 50 ft ³ / 991 – 1416 liters	

Standard Features:

- Stainless steel construction
- Modular plastic chain
- Hopper cleanout door

Available Options:

- Elevator extensions*
- Hopper extension for 50 ft³ capacity
- Continuous welded hopper seams (EH-35/50)
- Washdown motor
- Elevator and hopper covers
- Casters

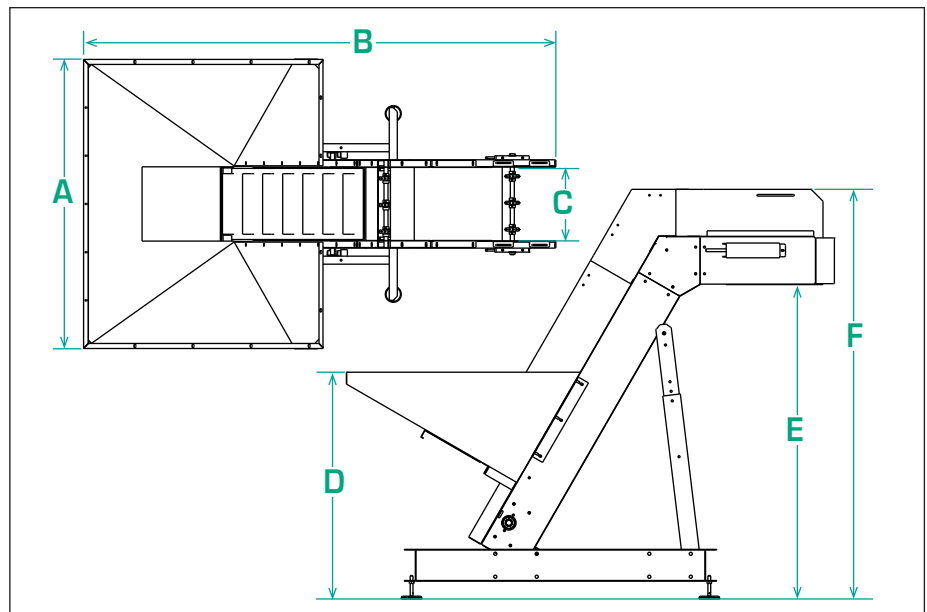

Product Specifications		ANSI	Metric
A	Overall Width	72.00"	1828.8mm
B	Overall Length	117.62"	2987.5mm
C	Modular Chain Width	17.72"	450.1mm
D	Hopper Load Height - EH-35	44.37"	1127.0mm
D	Hopper Load Height - EH-50	50.07"	1271.8mm
E	Discharge Height	76.46"	1942.1mm
F	Overall Height	93.64"	2378.5mm

* It is strongly recommended that the frame of the prefeeder be reinforced and/or additionally supported for elevator extensions of 36" or greater.